



Shadowline  
Wall Cladding System



## Contents

<b>1</b>	<b>Introduction .....</b>	<b>4</b>
<b>2</b>	<b>National Construction Code (NCC) 2022(Amdt.1).....</b>	<b>5</b>
2.1	Structural Performance, H1P1 & B1P1.....	6
2.2	Weatherproofing Performance, H2P2 & F3P1.....	6
2.3	Thermal Performance, (J4D6, H6D2(1)(b)(i), 13.2.5) .....	8
<b>3</b>	<b>System Component and Materials .....</b>	<b>8</b>
3.1	Other Materials.....	10
<b>4</b>	<b>Installation.....</b>	<b>12</b>
4.1	Horizontal Installation Procedure .....	15
4.2	Vertical Installation Procedure.....	16
<b>5</b>	<b>Typical Construction Details.....</b>	<b>17</b>
5.1	Horizontal Shadowline Boards .....	18
5.1.1	Concrete Slab Edge .....	18
5.1.2	Concrete Slab Rebate .....	19
5.1.3	Downpipe Fixing .....	20
5.1.4	Wall to Balcony .....	21
5.1.5	Panels Over Masonry Wall .....	22
5.1.6	Horizontal Expansion Joint .....	23
5.1.7	Vertical Expansion Joint .....	24
5.1.8	Meter Box Head .....	25
5.1.9	Meter Box Jamb .....	26
5.1.10	Meter Box Sill .....	27
5.1.11	Window Head .....	28
5.1.12	Window Jamb .....	29
5.1.13	Window Sill .....	30
5.1.14	Pipe Penetration .....	31
5.1.15	Eave Soffit .....	32
5.1.16	Garage / Bulkhead / Overhang / Drip .....	33
5.1.17	Metal Capping Parapet Wall to Box Gutter .....	34
5.1.18	Metal Capping Parapet Wall to Roof .....	35
5.1.19	Outside Corner .....	36
5.1.20	Inside Corner .....	37
5.1.21	Wall Over Roof .....	38
5.1.22	Outermost Edge .....	39
5.2	Vertical Shadowline Boards.....	40
5.2.1	Concrete Slab Edge .....	40
5.2.2	Concrete Slab Rebate .....	41
5.2.3	Downpipe Fixing .....	42
5.2.4	Wall to Balcony .....	43
5.2.5	Panels Over Masonry Wall .....	44
5.2.6	Horizontal Expansion Joint .....	45



5.2.7	Vertical Expansion Joint .....	46
5.2.8	Meter Box Head .....	47
5.2.9	Meter Box Jamb .....	48
5.2.10	Meter Box Sill .....	49
5.2.11	Window Head .....	50
5.2.12	Window Jamb .....	51
5.2.13	Window Sill .....	52
5.2.14	Pipe Penetration .....	53
5.2.15	Eave Soffit .....	54
5.2.16	Garage / Bulkhead / Overhang / Drip .....	55
5.2.17	Metal Capping Parapet Wall to Box Gutter .....	56
5.2.18	Metal Capping Parapet Wall to Roof .....	57
5.2.19	Outside Corner .....	58
5.2.20	Inside Corner .....	59
5.2.21	Wall Over Roof .....	60
5.2.22	Outermost Edge .....	61
<b>6</b>	<b>Manufacturer's Warranty.....</b>	<b>62</b>

## 1 Introduction

NewTechWood Shadowline Wall Cladding System is tested, appraised and certified to the requirements of the National Construction Code (NCC) 2022(Amdt.1) Volume Two, Building Code of Australia for external wall cladding applications.

This provides the peace of mind that the structural resistance, weathertightness and thermal performance of your new external wall cladding have been independently verified for Australian design conditions.

NewTechWood Shadowline Wall Cladding boards are a composite timber cladding manufactured from 60% recycled wood fibre, 30% HDPE, and 10% pigment/additives to provide a superior performing finished product.

For durability and longevity, you can't go past NewTechWood fully capped composite timber wall cladding. It is highly stain and UV-resistant, reinforcing its enduring qualities, plus, it requires virtually no maintenance. The ultimate solution for interior and exterior decorative features, NewTechWood wall cladding is a perfect architectural feature for building projects of any size.

Manufactured to exacting quality controls regularly independently audited as part of the CodeMark Australia Certification Scheme.

Newtechwood Shadowline Wall Cladding System benefits:



Quality Durability Versatility Sustainability

NewTechWood Shadowline Wall Cladding boards are naturally termite resistant, will not rot, crack, warp or splinter, are impervious to water absorption, and never require painting or coating.

NewTechWood Shadowline Wall Cladding System utilises concealed clip fixings to hold cladding boards perfectly in place while support air circulation, water vapour dissipation and condensation management.

NewTechWood Shadowline Wall Cladding System may be installed either horizontally or vertically clip-fixed onto battens.

This manual is to be used by designers and builders. It describes NewTechWood Shadowline Wall Cladding System performance, installation and typical construction detailing requirements.

Product selection and installation must be carried out by a competent carpenter or other tradesman under the direction of a Builder. All involved must be conversant with the installation method and have access to all relevant technical information.

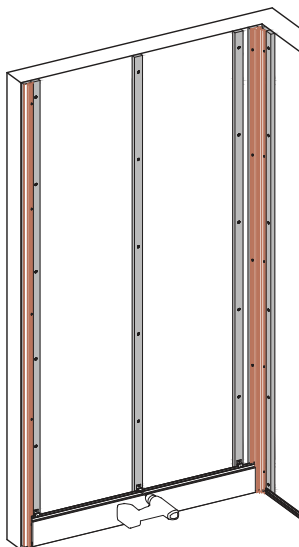

Horizontal boards on vertical battens

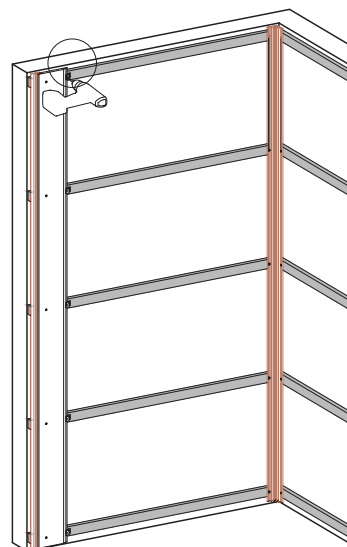

Vertical boards on horizontal battens



## 2 National Construction Code (NCC) 2022(Amdt.1)

NewTechWood Shadowline Wall Cladding System is CodeMark certified to the requirements of NCC 2022(Amdt.1), Volumes One & Two, Building Code of Australia for:

**Structure:** (H1P1, B1P1 Structural stability and resistance to actions), tested strength and appraised for design wind pressures up to  $\pm 3.01$  kPa including AS 4055:2021 Wind Class N4w.

**Weatherproofing:** (H2P2, F3P1 Weatherproofing), tested for water penetration and appraised for serviceability design wind pressures up to  $+0.82/-1.23$  kPa including AS 4055:2021 Wind Class N4w.

**Energy Efficiency:** (Vol. One J4D6, Vol. Two H6D2(1)(b)(i), Housing Provisions 13.2.5 External Walls). NewTechWood Shadowline Wall Cladding System achieves high Total R-values which may be used to satisfy J4D6 & H6D2(1)(b)(i) external wall insulation requirements, or as input to house energy rating software to achieve a NatHERS star rating.

NewTechWood Shadowline Wall Cladding System complies with the National Construction Code (NCC) 2022(Amdt.1) as a Performance Solution to A2G2. As such, projects require completion of a Performance Based Design Brief (PBDB) & Performance Solution Report (PSR) in addition to the CodeMark Certificate.

Project designers must consider:

- All relevant performance requirements and project specific needs (e.g. structure, fire, weatherproofing, dampness, bushfire, condensation and energy efficiency.)
- AS 4055 Wind Class and wind pressures.
- Expansion joint locations; and
- Other local & state government requirements.

Details of compliance of the NewTechWood Shadowline Wall Cladding System for structure (wind strength), weatherproofing and energy efficiency are detailed in this Installation Guide.

<b>NewTechWood Shadowline Wall Cladding System</b>			
AS 4055 Wind Classification	Maximum Batten Spacing (mm)	AS/NZS 1170.2 Maximum Design Wind Pressures (kPa)	
		Serviceability (SLS)	Strength (ULS)
N1w, N2w, N3w	500	+0.82 / -1.23	2.60
N4w	500		3.01

## 2.1 Structural Performance, H1P1 & B1P1

NewTechWood Shadowline Wall Cladding System is tested and certified for AS 4055 Wind Classifications N1w to N4w (excluding AS 4055 Wind Classifications N5w, N6w, C1w, C2w, C3w and C4w). This includes AS/NZS 1170.2 Design Ultimate Limit State Wind Pressures (non-cyclonic) between +2.01kPa & -3.01kPa, and Serviceability Limit State Wind Pressures between +0.82 to -1.23kPa.

The design wind loads for any particular building are site specific and must be determined by the design professional responsible for the project.

General requirements / limitations include recognition that NewTechWood Shadowline Wall Cladding System:

- is not intended to act as wall bracing. Resistance to the design racking loads must be accommodated by other means prior to installation of the wall wrap.
- is not load-bearing and control joints are required at regular intervals to allow for building movement.
- shall be fixed to framing at a maximum 600mm spacing.

Note: To achieve Wind Classification in accordance with AS 4055, Wind Loads for Housing, a house shall;

- o have a maximum distance of 6.0m from ground level to the underside of eaves; and,
- o have a maximum distance from ground level to the highest point of the roof (not including chimneys) of 8.5m; and,
- o have a maximum width (including roofed verandas, but excluding eaves) of 16.0m, and the maximum length shall not exceed five times the width; and,
- o not have a roof pitch greater than 35 degrees.

Buildings that do not meet these requirements shall be designed to resist wind pressures determined in accordance with AS/NZS 1170.2.

## 2.2 Weatherproofing Performance, H2P2 & F3P1

NewTechWood Shadowline Wall Cladding System complies with the NCC performance requirements for weatherproofing confirmed based on testing in accordance with the NCC weatherproofing verification methods H2V1 & F3V1.

Weatherproofing performance has been verified for external walls with;

- Serviceability Limit State (SLS) design wind pressures up to AS 4055, Wind Classification N4 (equivalent to AS/NZS 1170.2 design SLS pressures of +0.82 kPa to -1.23 kPa); and
- Windows that comply with AS 2047-Windows and external glazed doors in buildings; and
- A Risk Score of 20 or less determined in accordance with NCC 2022(Amdt.1), Volume Two, Table H2V1a & Volume One Table F3V1a-Risk factors and scores, as:

Risk factor	Category	Risk severity	Score
Wind region	Region A0-5 (AS/NZS 1170.2)	Low to medium	0
	Region B1-2 (AS/NZS 1170.2)		
	Region C (AS/NZS 1170.2)	High	1
	Region D (AS/NZS 1170.2)	Very high	2
Number of storeys	One storey	Low	0
	Two storeys in part	Medium	1
	Two storeys	High	2
	More than two storeys	Very high	4
Roof/wall junctions	Roof-to-wall junctions fully protected	Low	0
	Roof-to-wall junctions partially exposed	Medium	1
	Roof-to-wall junctions fully exposed	High	3
	Roof elements finishing within the boundaries formed by the external walls	Very high	5
Eaves width	Greater than 600 mm for single storey	Low	0
	451-600 mm for single storey; or	Medium	1
	Greater than 600 mm for two storey		
	101-450 mm for single storey; or	High	2
	451-600 mm for two storey; or		
	Greater than 600 mm for above two storey		
	0-100 mm for single storey; or	Very high	5
	0-450 mm for two storey; or		
Less than 600 mm for above two storey			
Envelope complexity	Simple shape with single cladding type	Low	0
	Complex shape with no more than two cladding types	Medium	1
	Complex shape with more than two cladding types	High	3
	As for high risk but with fully exposed roof-to-wall junctions	Very high	6
Decks, porches and balconies	None	Low	0
	Timber slat deck or porch at ground level		
	Fully covered in plan view by roof	Medium	2
	Timber slat deck attached at first or second floor level		
	Balcony exposed in plan view at first floor level	High	4
	Balcony cantilevered at first floor level		
	Balcony exposed in plan view at second floor level or above	Very high	6
Balcony cantilevered at second floor level or above			

(Attribution: © Commonwealth of Australia and the States and Territories 2022, published by the Australian Building Codes Board.)

### 2.3 Thermal Performance, (J4D6, H6D2(1)(b)(i), 13.2.5)

NewTechWood Shadowline Wall Cladding Systems incorporating vertical or horizontal panels, breathable wall wrap and 10mm plasterboard lining achieve the following Total R-values in accordance with AS/NZS 4859.1:2018.

These Total R-values may either; satisfy the minimum requirements of NCC 2022(Amdt.1), Volume One J4D6, Volume Two H6D2(1)(b)(i) & Housing Provisions 13.2.5 external wall insulation requirements; or, may be used as inputs to house energy rating software to achieve an energy rating.

NewTechWood Shadowline Wall Cladding System (with 90mm R2.5 batts)		Total R-value (m <sup>2</sup> .K/W)	
		Winter (Heat flow outwards)	Summer (Heat flow inwards)
Horizontal	Timber Frame	2.69	2.53
	Steel Frame	2.12	2.01
Vertical	Timber Frame	2.66	2.51
	Steel Frame	2.03	1.90

### 3 System Component and Materials

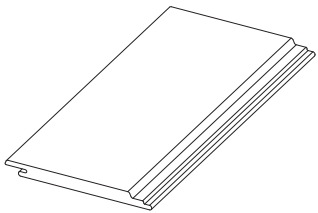
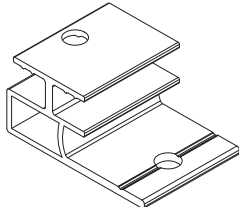
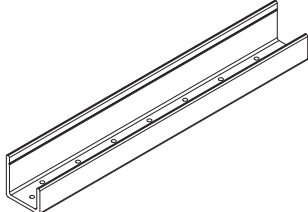
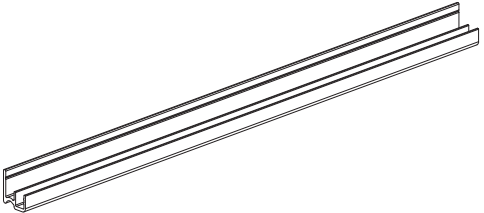

Wall Cladding Parts supplied by NewTechWood.

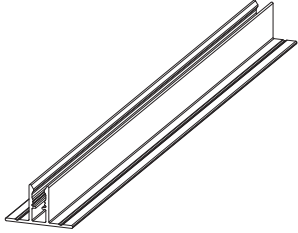
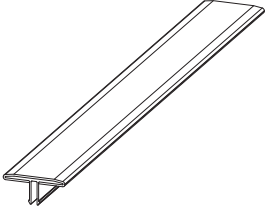
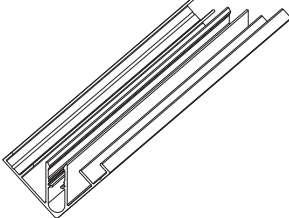
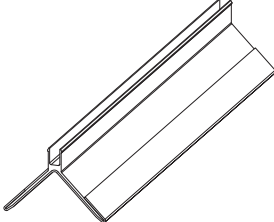
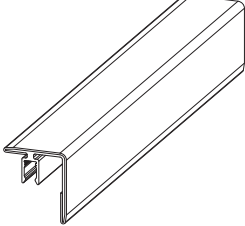
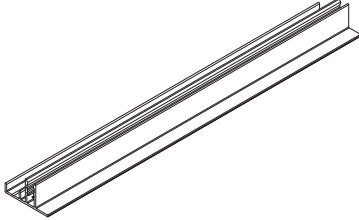
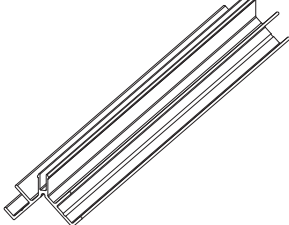

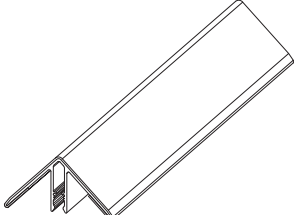
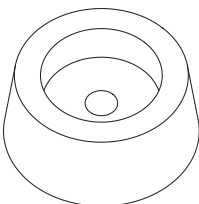
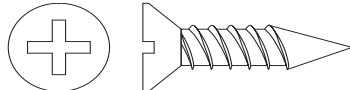
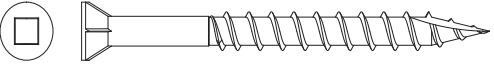

Part Number	Purpose	Picture
US31	Shadowline Wall Cladding Board	
AW08	Cladding Clip	
CA42 (interchangeable with AW02)	J-Trim, Starter Strip used at the base of the wall, top of the wall, around windows & large penetrations.	
AW02 (interchangeable with CA42)	Starting Trim, used at the base of the wall, top of the wall, around windows & large penetrations.	

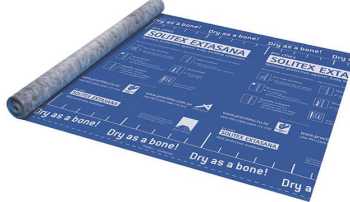
Part Number	Purpose	Picture
AA45	H-Trim Base, used at vertical and horizontal joints.	
CA49	H-Trim Cover, used at vertical and horizontal joints.	
AA46	Inside Corner Trim Base, used at internal corners	
CA50	Inside Corner Trim Cover, used at internal corners	
CA48	F-Trim Cover, used at the end of the wall.	
AA44	F-Trim Base, used at the end of the wall.	
AA47	Outside Corner Trim Base, used at external corners	

Part Number	Purpose	Picture
CA51	Outside Corner Trim Cover, used at external corners	
T7	Stopper, used to pack under the last wall cladding board at a joint.	
WJ063	Screw, used when locking the board into AW08, M3x12mm, SS304	
Screw - Cladding board face-fixing to timber battens	8g x 50mm, SS304, Colour head, used for face-fixing first/last boards next to trims	

### 3.1 Other Materials

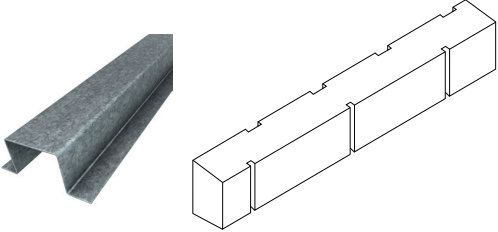
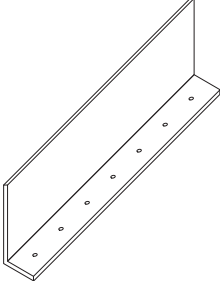
Material Description	Specification	Picture
Breathable Wall Wrap	Solitex Extasana Wall Weather Resistive Barrier	
Wall Wrap Compatible Tape	Tescon Extora Weathertight Sealing Tape used at joins of Solitex Extasana	
Wall Wrap Compatible Patches	Pro clima NAIDECK Patches to all screws penetrating	

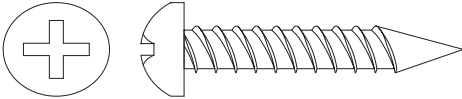
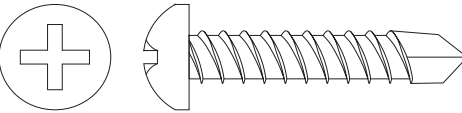
Material Description	Specification	Picture
Wall Wrap Compatible Penetration	TESCON EXTONSEAL sill tape used around framed openings and perimeter of Solitex Extasana	
Adhesive Sealant	Orcon All Round General Purpose Sealant or similar.	
Cavity Batten	Steel Top-Hat (horizontal), 50x25x0.75mm BMT G550, OR Timber (horizontal or vertical-onstud), 70x35mm, H3 treated, MGP10, chamfered top edge & castellated to provide minimum open area of 1000mm <sup>2</sup> /m.	
Cavity Closer	60x25x0.42mm BMT Z150, Steel Angle with phi 3mm holes providing open area of 1000mm <sup>2</sup> /m	
Screw - Batten to frame	Steel Top-hat baten to: - Steel frame – 12g x 25mm, Hex head self-drill, min. Class 3, 2 per stud. - Timber Frame - 12g x 60mm, SS304 bugle batten, 2 per stud. Timber batten to Timber/Steel frame – 12g x 60/80mm, SS304 bugle batten, 2 per stud	
Screw – Clip / Trim to Timber Batten	10g x 25mm, SS304 Self-Tapping pan head.	
Screw – Clip / Trim to Steel Batten	10g x 20mm, SS304 Self-Tapping pan head.	

## 4 Installation

### IMPORTANT: Read All Sections Before You Start

NewTechWood Shadowline Wall Cladding System must be installed in accordance with this manual by experienced installers under the direction of a professional builder.

Prior to installing any composite cladding system, it is recommended that you check with local building codes for any special requirements or restrictions. The diagrams and instructions outlined in this guide are for illustration purposes only and are not meant or implied to replace a licensed professional. Any construction or use of NewTechWood must be in accordance with all local zoning and/or building codes. The consumer assumes all risks and liability associated with the construction and use of this product.

### Safety

When dealing with any type of construction project, it is necessary to wear appropriate safety equipment to avoid any risk of injuries. NewTechWood recommends, but is not limited to the following safety equipment, when handling, cutting, and installing NewTechWood: gloves, a respiratory protection, long sleeves, pants, and safety glasses.

### Tools

Standard woodworking tools may be used. It is recommended that all blades have a carbide tip. Standard stainless steel or acceptable coated deck screws and nails are recommended.

### Environment

A clean, smooth, flat, and strong surface is needed to install NewTechWood's products correctly. Please check with local building codes before ever installing any type of cladding. If installation does not occur immediately, NewTechWood's products need to be put on a flat surface at all times. It should NEVER be put on a surface that is NOT flat.

### Planning

Plan a layout for your cladding before starting it to ensure the best possible looking cladding for your project. Building codes and zoning ordinances generally apply to permanent structures, meaning anything that is anchored to the ground or attached to the house. So nearly every kind of cladding requires permits and inspections from a local building department. We recommend drawing out a site plan of your proposed project that you intend to do to minimize errors and make your perfect wall cladding.

**Pressure washing on a scrap piece of material before using a pressure washer on the wall cladding to ensure that your settings will not damage the Ultrashield coating.**

### Static

Static can also be more prevalent in areas that are of higher altitude because the humidity is lower. For these areas, be careful of using conductive objects such as metal railing and chairs as static shocks might occur more often. A potential way to lower the amount of static shocks occurring is to apply Staticide ([www.aclstaticide.com](http://www.aclstaticide.com)) on your deck or use anti-static mats before doorways.

### Heat and Fire

Excessive heat on the surface of NewTechWood products from external sources such as but not limited to fire or reflection of sunlight from energy efficient window products. Low-emissivity (Low-E) glass can potentially harm NewTechWood products. Low-E glass is designed to prevent passive heat gain within a structure and can cause unusual heat build-up on exterior surfaces. This extreme elevation of surface temperatures, which exceeds that of normal exposure, can possibly cause NewTechWood products to melt, sag, warp, discolour, increase expansion/ contraction, and accelerate weathering.

Current or potential NewTechWood customers that have concerns about possible damage by Low-E glass should contact the manufacturer of the product, which contains Low-E glass for a solution to reduce or eliminate the effects of reflected sunlight.



## Framing

Wall Framing should be provided in accordance with:

- AS 1684.2 Residential Timber Framed Construction – Non-cyclonic areas, or
- NASH Standard Residential and low-rise steel framing, or
- another appropriate standard.

The design, specification, supply and construction of steel or timber wall framing does not form part of the NewTechWood Shadowline Wall Cladding System.

## Minimum Ground Clearance

The designer and builder are responsible for ensuring the minimum ground clearance from the bottom of the wall cladding to the adjoining finished ground level is in accordance with all relevant building code, standards, and local government regulations. E.g. 100mm in low rainfall areas or sandy well-drained areas, 50mm above impermeable (paved or concreted) areas that slope away from the building, or 150mm in any other case.

## Breathable Wall Wrap

Vapour permeable wall wrap must be installed in accordance with the manufacturers' instructions.

Wall Wrap Compatible Tape is required to seal the Breathable Wall Wrap at all joints, openings and around the perimeter of the wall frame. Wall Wrap Compatible Tape must always be applied in accordance with the manufacturers' instructions ensuring surfaces are clean and dry and by applying pressure to ensure firm contact with the substrate. Wall Wrap Compatible Tape must only be applied to materials that are already mechanically fixed.

All holes made in the Breathable Wall Wrap must be patched with Wall Wrap Compatible Patches.

## Flashings

The designer and builder are responsible for ensuring drainage paths and flashings are provided to prevent rain water ingress behind cladding boards and to provide drainage to the outside of the building.

## Battens

Batten must have a minimum thickness of 25 mm.

Battens are fixed into position at a maximum spacing of 500 mm. All battens need to be flat and levelled against the wall surface use shims if necessary.

Each cladding board must be supported on battens with at a maximum spacing of 500 mm.

## Fasteners

All screws that are face fixed should always be stainless steel. It is recommended to predrill the holes slightly larger than the screw's shank size on the cladding profiles and the trims to allow for expansion and contraction response to temperature.

When fastening NewTechWood all screws that are face fastened should always be driven in at a 90 degree angle to the cladding surface.

Use white chalk, straight boards, or string lines as templates for straight lines. Coloured chalk will permanently stain NewTechWood and are highly not recommended.

All fixings through NewTechWood material must be pre-drilled.

### Joint Gaps and Clearances for Expansion and Contraction

NewTechWood cladding boards will experience expansion and contraction with changes in temperature. Expansion and contraction are most significant where extreme temperature changes occur. Fastening the cladding boards according to the gapping requirements noted in the following table accommodates for this movement.

		Length (m)								
		1	2.44	2.8	3	3.66	4	4.88	5.4	
Installation Temperature (°C)	0	1.4	3.4	3.9	4.2	5.1	5.6	6.8	7.6	Gap (mm)
	5	1.2	2.9	3.4	3.6	4.4	4.8	5.9	6.5	
	10	1.0	2.4	2.8	3.0	3.7	4.0	4.9	5.4	
	15	0.8	2.0	2.2	2.4	2.9	3.2	3.9	4.3	
	20	0.6	1.5	1.7	1.8	2.2	2.4	2.9	3.2	
	25	0.4	1.0	1.1	1.2	1.5	1.6	2.0	2.2	
	30	0.2	0.5	0.6	0.6	0.7	0.8	1.0	1.1	

**Note:**

1. Values are for total gap required. If boards have a gap at each end, then halve the value shown.
2. If you are still unsure of what gapping to use, contact the manufacturer and they will give you the correct gapping requirements based on your environment and area.

The designer is responsible for determining the correct locations for expansion joints. Expansion joints are typically required at each floor level and at all joints between different building construction materials.

### Locking Screws preventing Wall Cladding Board movement

Every AW-08 clip comes with a separate hole for locking the board in position due to expansion and contraction.

**ONLY ONE LOCKING SCREW IS USED PER BOARD**, and the board to expand and contract readily in the other direction.

**DO NOT LOCK EVERY CLIP.** General rule of thumb is every board will only need one locking/fixing point.

Horizontal boards should be locked at mid-length Clip.

Vertical boards should be locked at the top Clip.

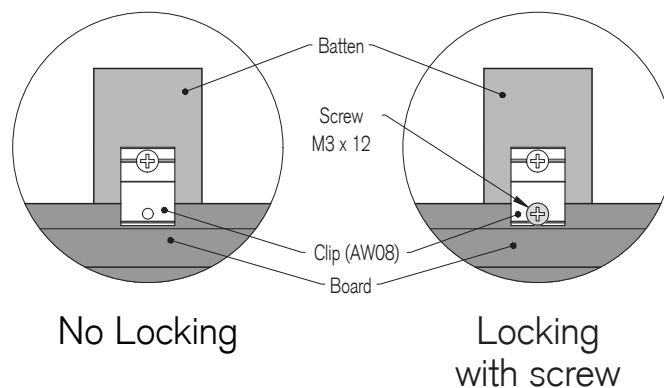

### Board End Joints

At butt joints between boards it is recommended to use H-Trim joiners, see *Typical Construction Detail – Horizontal Expansion Joint and Vertical Expansion Joint*.

## 4.1 Horizontal Installation Procedure

### Step 1: Framing –

- Measure and Chalk the battens at maximum 500mm spacings. Timber Battens may be used on-stud, or span between horizontal structural framing at a maximum spacing of 600mm.

### Step 2: Framing - Battens Installation –

- Screw-fix Timber Battens with 1 screw at maximum 600mm spacing, in accordance with the *System Components and Materials* section.
- Ensure required minimum ground clearance is maintained as specified.

### Step 3: Install Trims as required –

- Leave a minimum 5mm gap between all trims.
- Screw-fixed to Timber Battens at maximum 500mm spacing. Ensure each board is fixed with a Clip immediately adjacent to all trims.
- J-Trim / Aluminium Trim Base - along the base of the wall, ensuring required minimum ground clearance is maintained as specified, see *Typical Construction Detail – Concrete Slab Edge*.
- Inside Corner Trim Base, see *Typical Construction Detail – Inside Corner*,
- Outside Corner Trim Base, see *Typical Construction Detail – Outside Corner*,
- F-Trim Base, see *Typical Construction Detail – Outermost Edge*, and
- H-Trim Base, see *Typical Construction Detail – Horizontal Expansion Joint and Vertical Expansion Joint*.

### Step 4: Install the Cladding Boards –

- Measure distance between trims and cut boards to length leaving required expansion/contraction gaps. Fix with Clips and screws, including locking screw at mid-length of each board.

### Step 5: Install the last Boards –

- Face-fixing as required, determined by the wall height, see *Typical Construction Detail – Eave Soffit*.

### Step 6: Install the Capped Aluminium Covers to Base Trims to finish the walls.

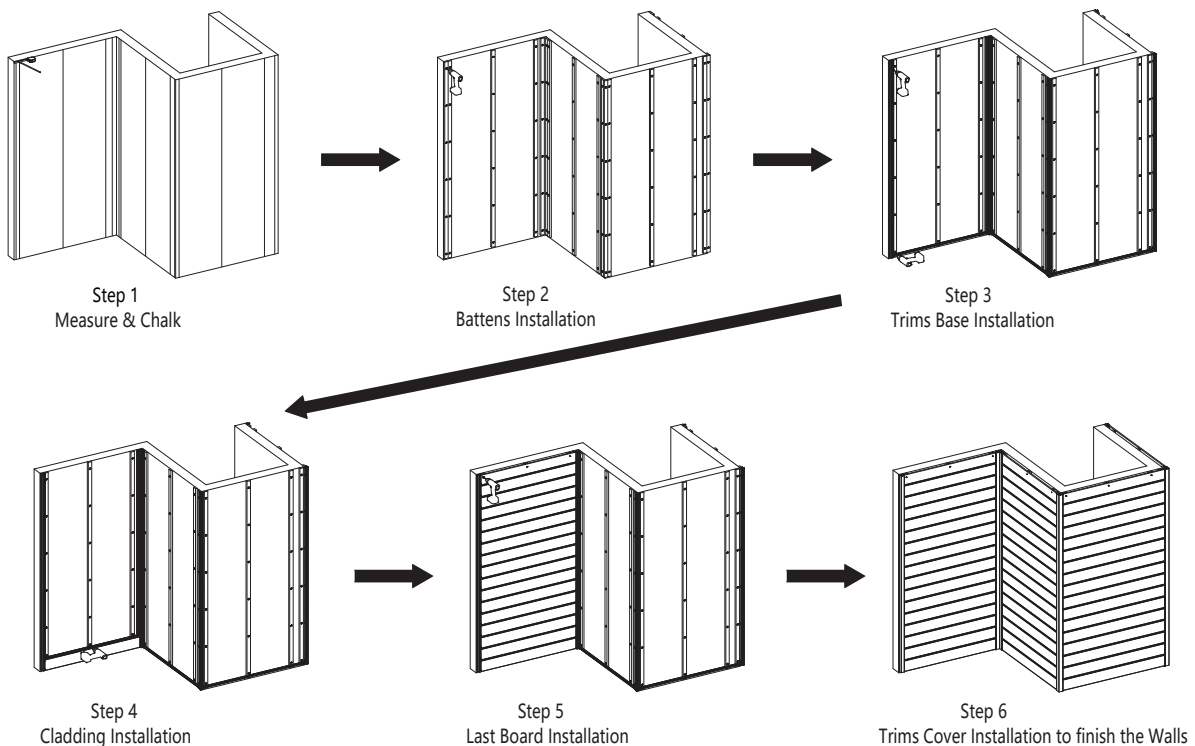

## 4.2 Vertical Installation Procedure

Step 1: Framing –

- Measure and Chalk the battens at maximum 500mm spacings. Steel Top-Hats or Timber Battens may be used.

Step 2: Framing - Battens Installation –

- Screw-fix battens, Steel top-hat battens with 2 screws per stud, Timber battens with 1 screw in accordance with the *System Components and Materials* section.
- Ensure required minimum ground clearance is maintained as specified.

Step 3: Install Trims as required –

- Leave a minimum 5mm gap between all trims.
- Screw-fixed at maximum 500mm spacing. Ensure each board is fixed with a Clip immediately adjacent to all trims.
- J-Trim / Aluminium Trim Base - along the base of the wall, ensuring required minimum ground clearance is maintained as specified, see *Typical Construction Detail – Concrete Slab Edge*.
- Inside Corner Trim Base, see *Typical Construction Detail – Inside Corner*,
- Outside Corner Trim Base, see *Typical Construction Detail – Outside Corner*,
- F-Trim Base, see *Typical Construction Detail – Outermost Edge*, and
- H-Trim Base, see *Typical Construction Detail – Horizontal Expansion Joint and Vertical Expansion Joint*.

Step 4: Install the Cladding Boards –

- Measure distance between trims and cut boards to length leaving required expansion/contraction gaps. Fix with Clips and screws, including locking screw at the top of each board.

Step 5: Install the last Boards –

- Face-fixing as required, determined by the wall width, see *Typical Construction Detail – Outermost Edge, Outside Corner, Inside Corner*.

Step 6: Install the Capped Aluminium Covers to Base Trims to finish the walls.

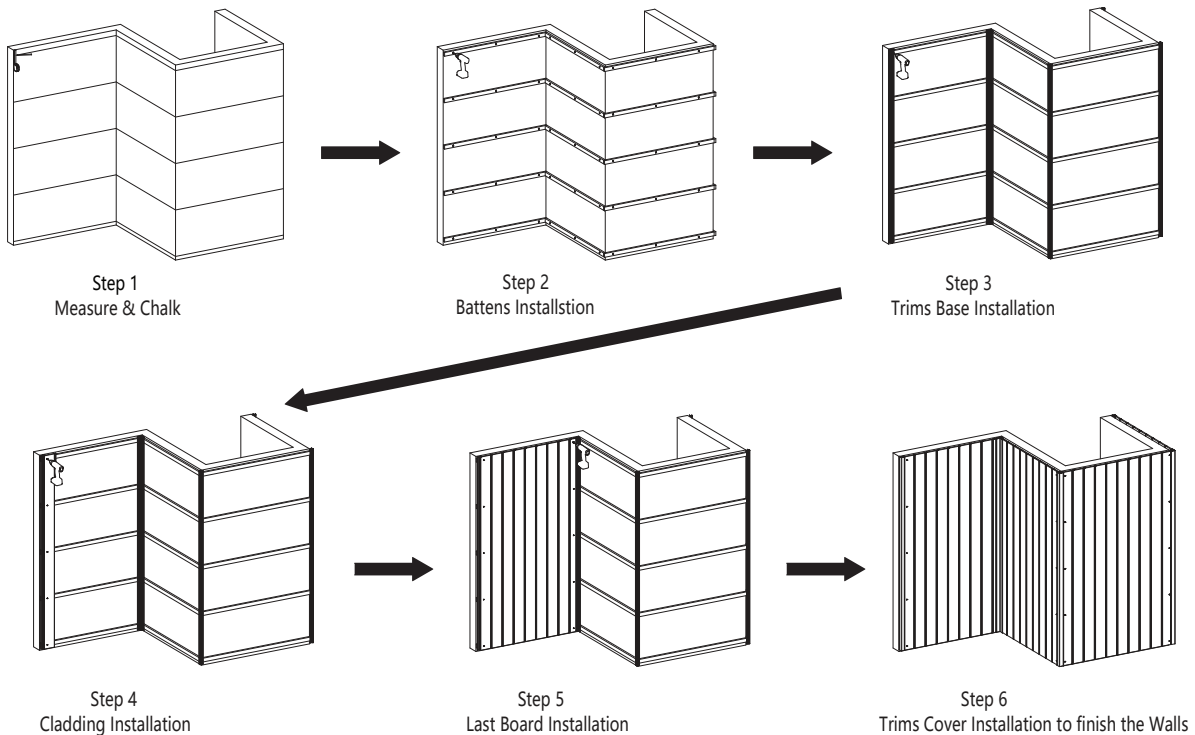

## 5 Typical Construction Details

NewTechWood Shadowline Wall Cladding System must be installed in strict accordance with this Installation Guide and comply with all relevant building code, standards, and local government regulations.

These typical construction details are provided as a guide for construction industry professionals. These typical construction details do not constitute a project specific specification and should only be used within the context of project specifications.

Modifications to these drawings shall not be made without the approval of NewTechWood.

5.1 Horizontal Shadowline Boards

5.1.1 Concrete Slab Edge

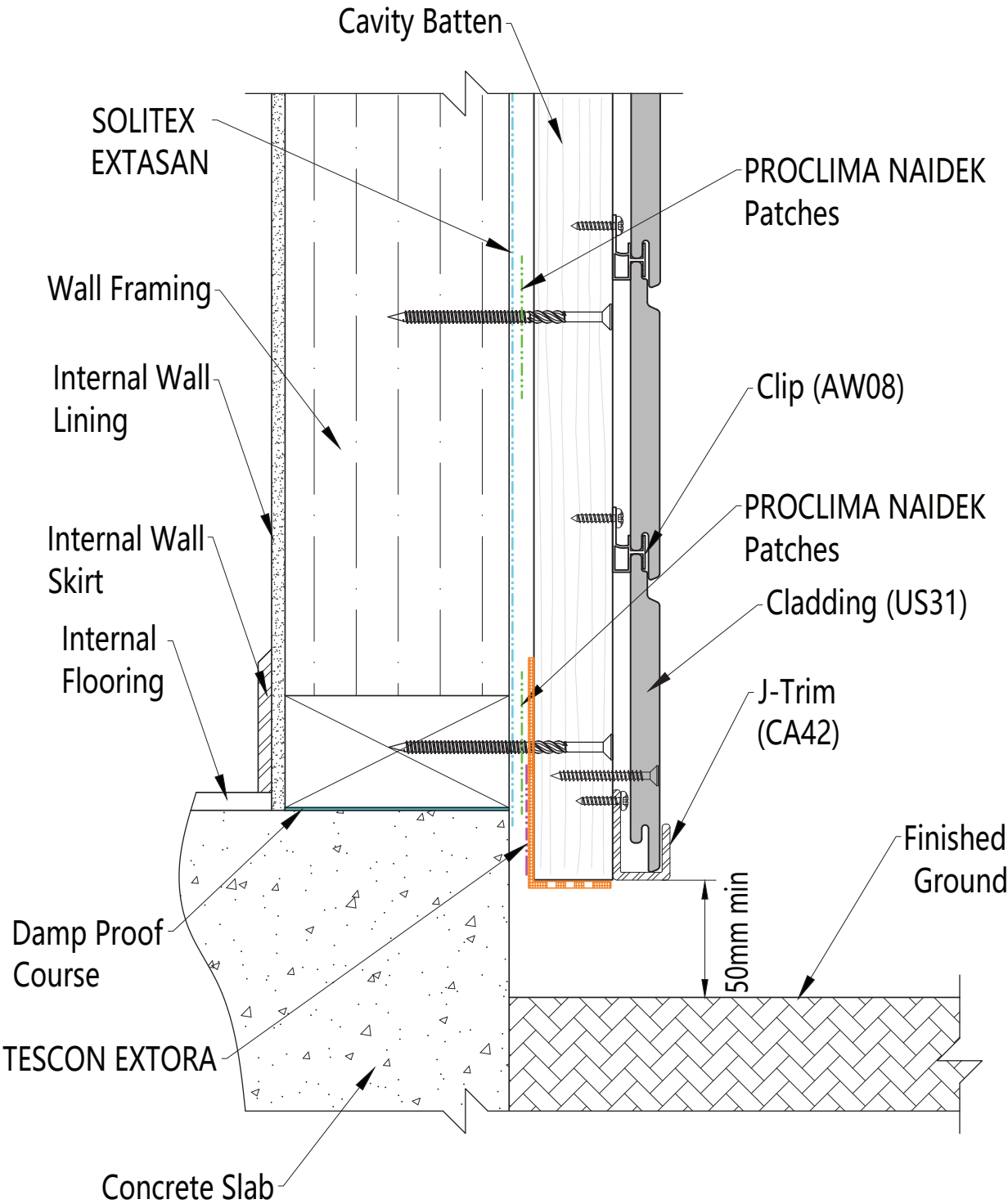

5.1.2 Concrete Slab Rebate

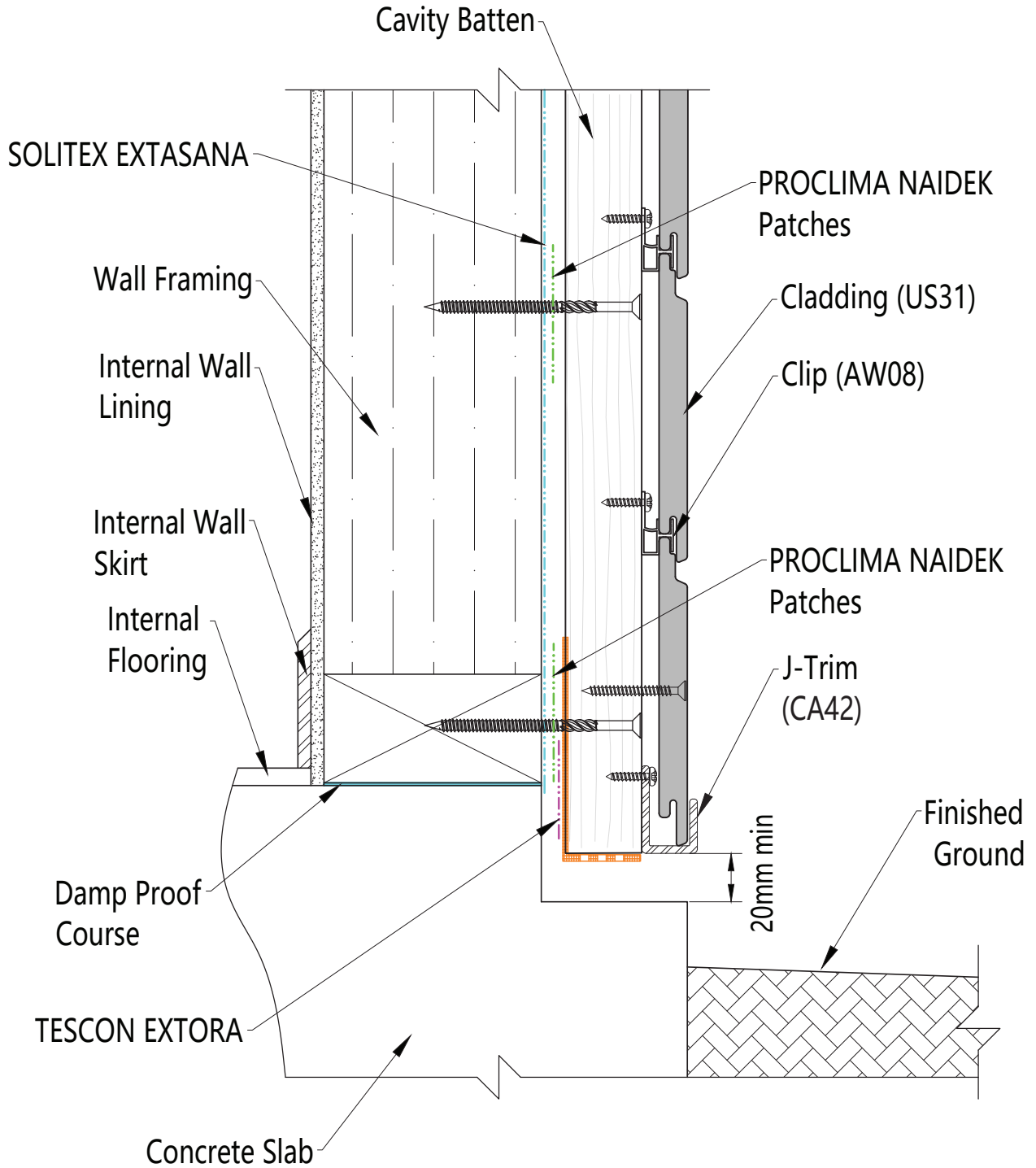

### 5.1.3 Downpipe Fixing

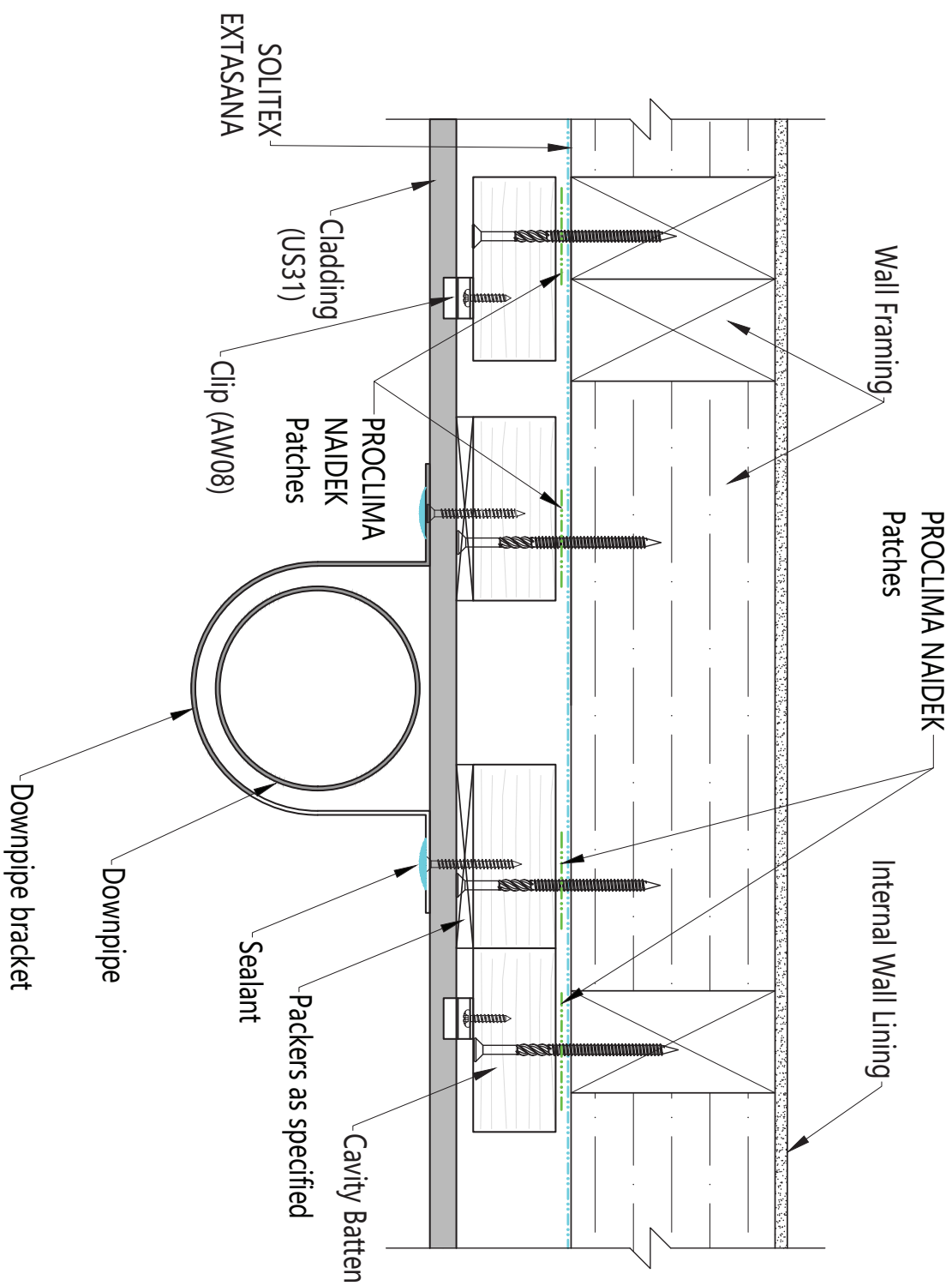



5.1.4 Wall to Balcony

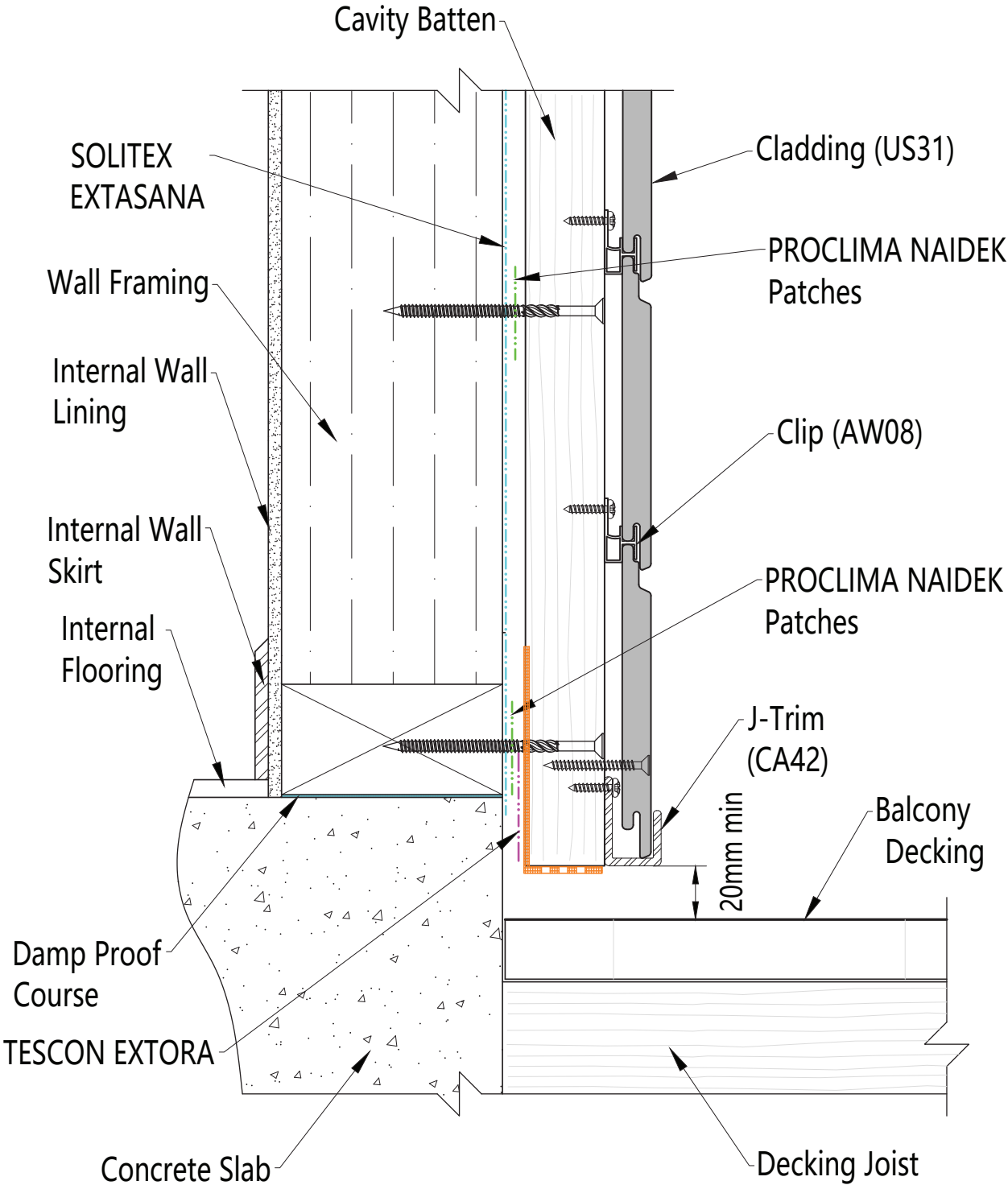

5.1.5 Panels Over Masonry Wall

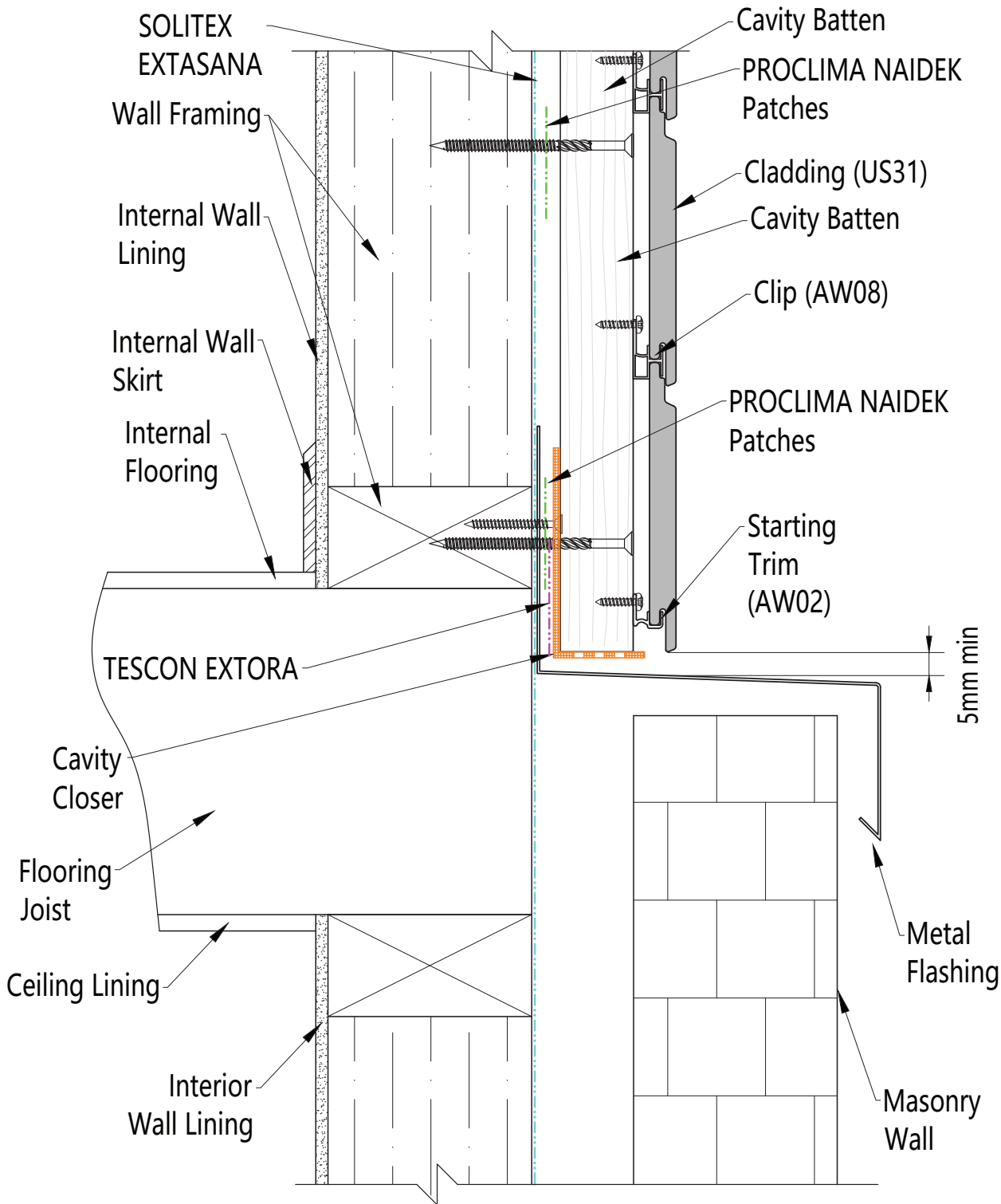

5.1.6 Horizontal Expansion Joint

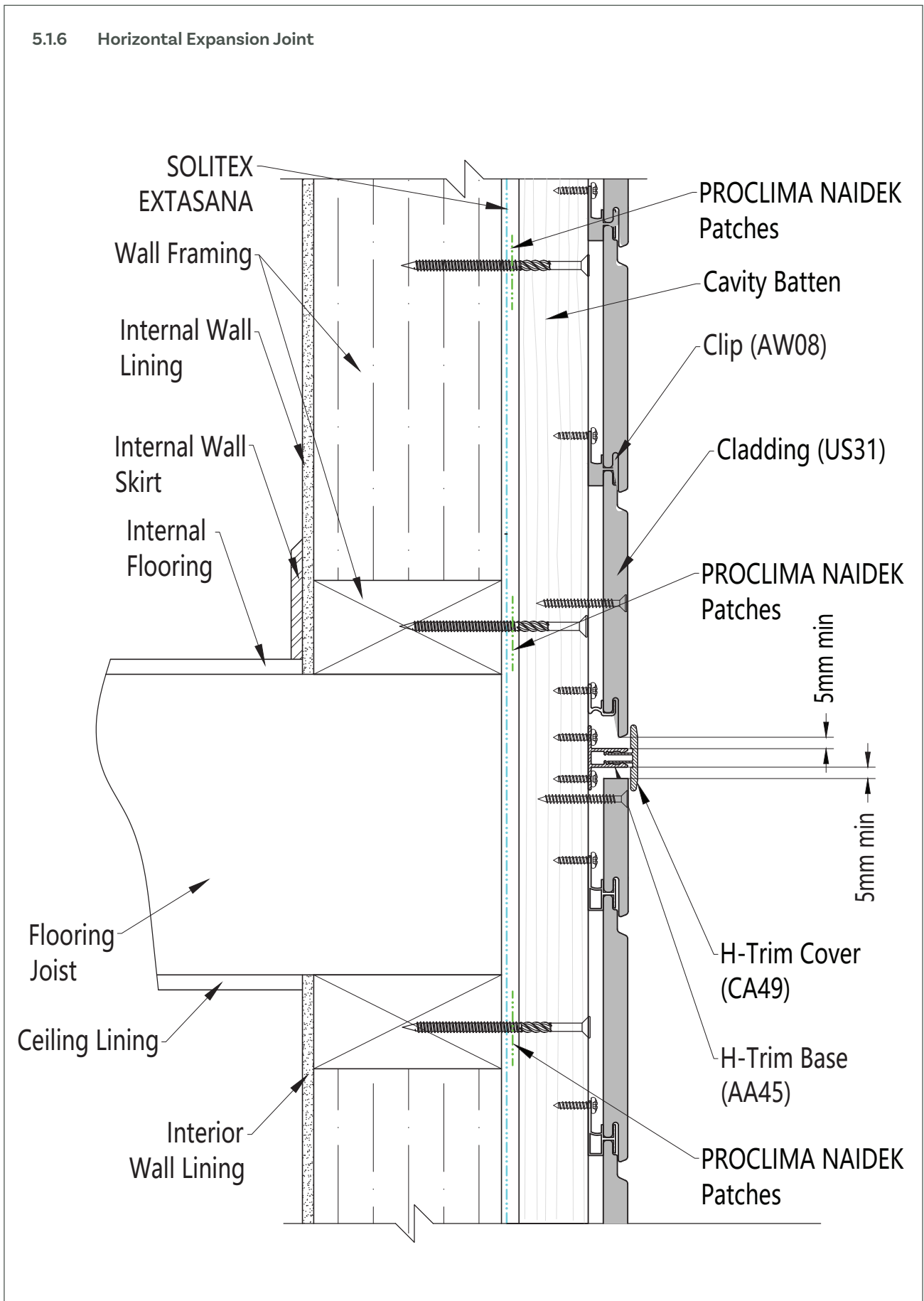

5.1.7 Vertical Expansion Joint

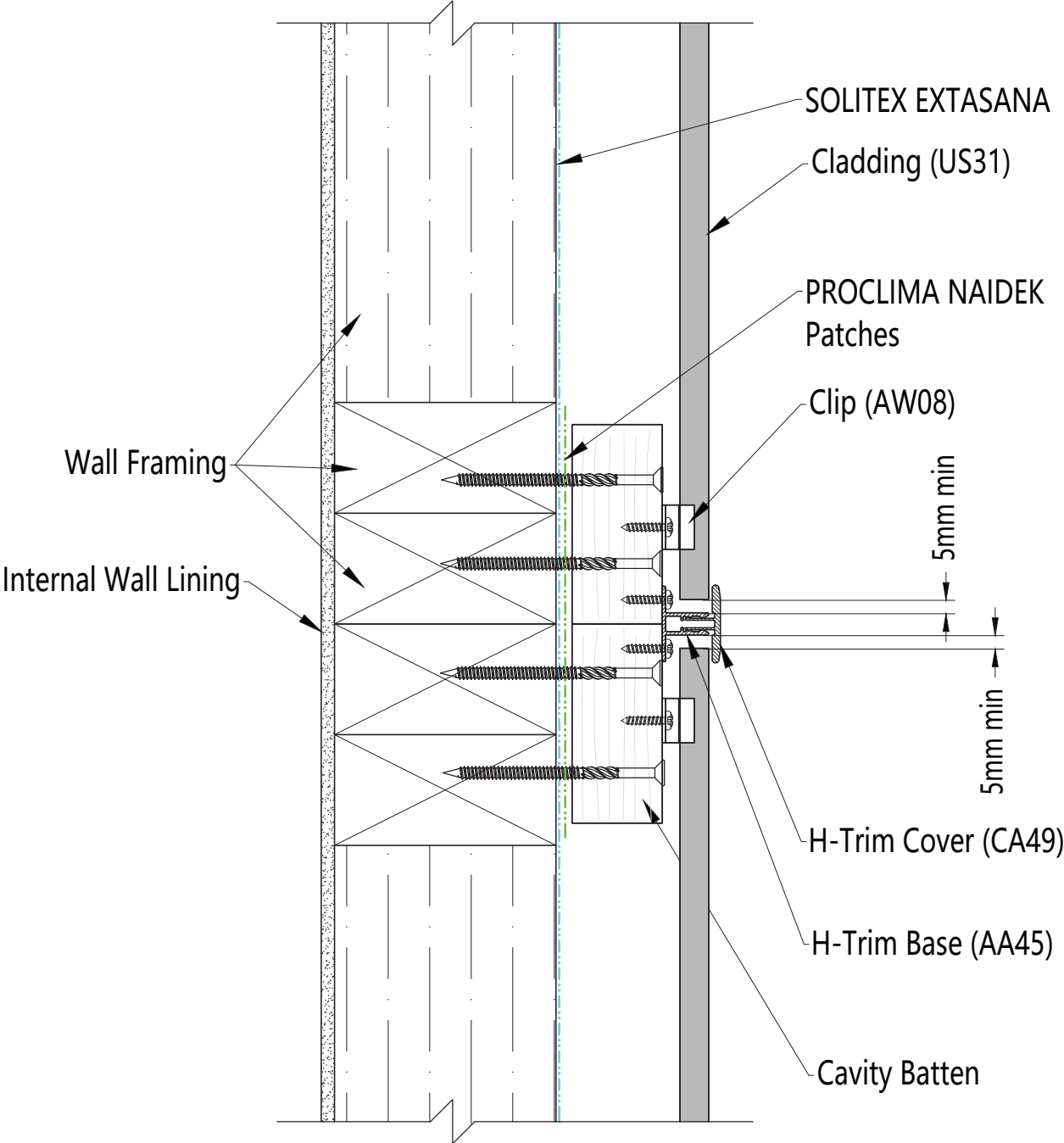

5.1.8 Meter Box Head

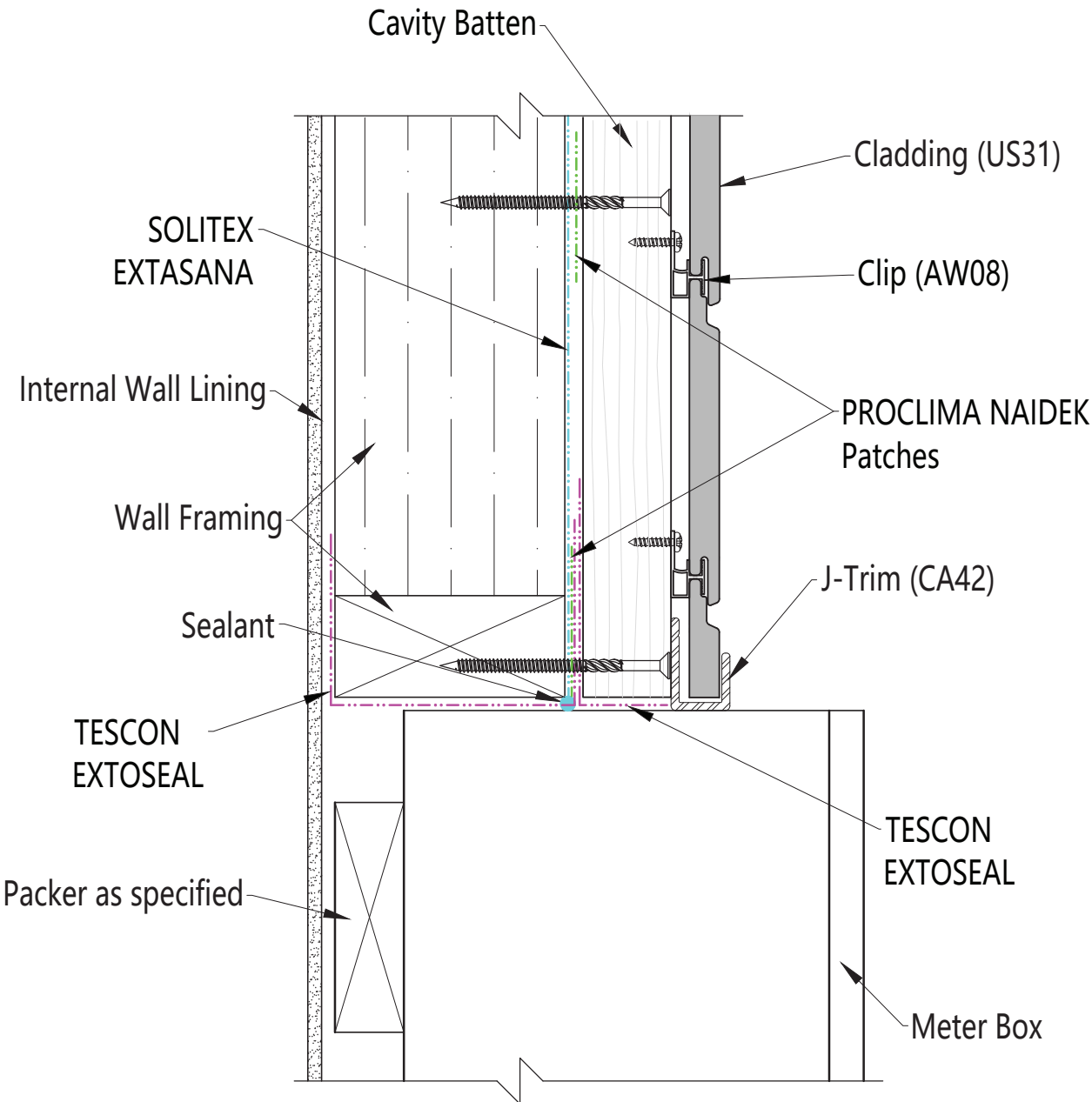

5.1.9 Meter Box Jamb

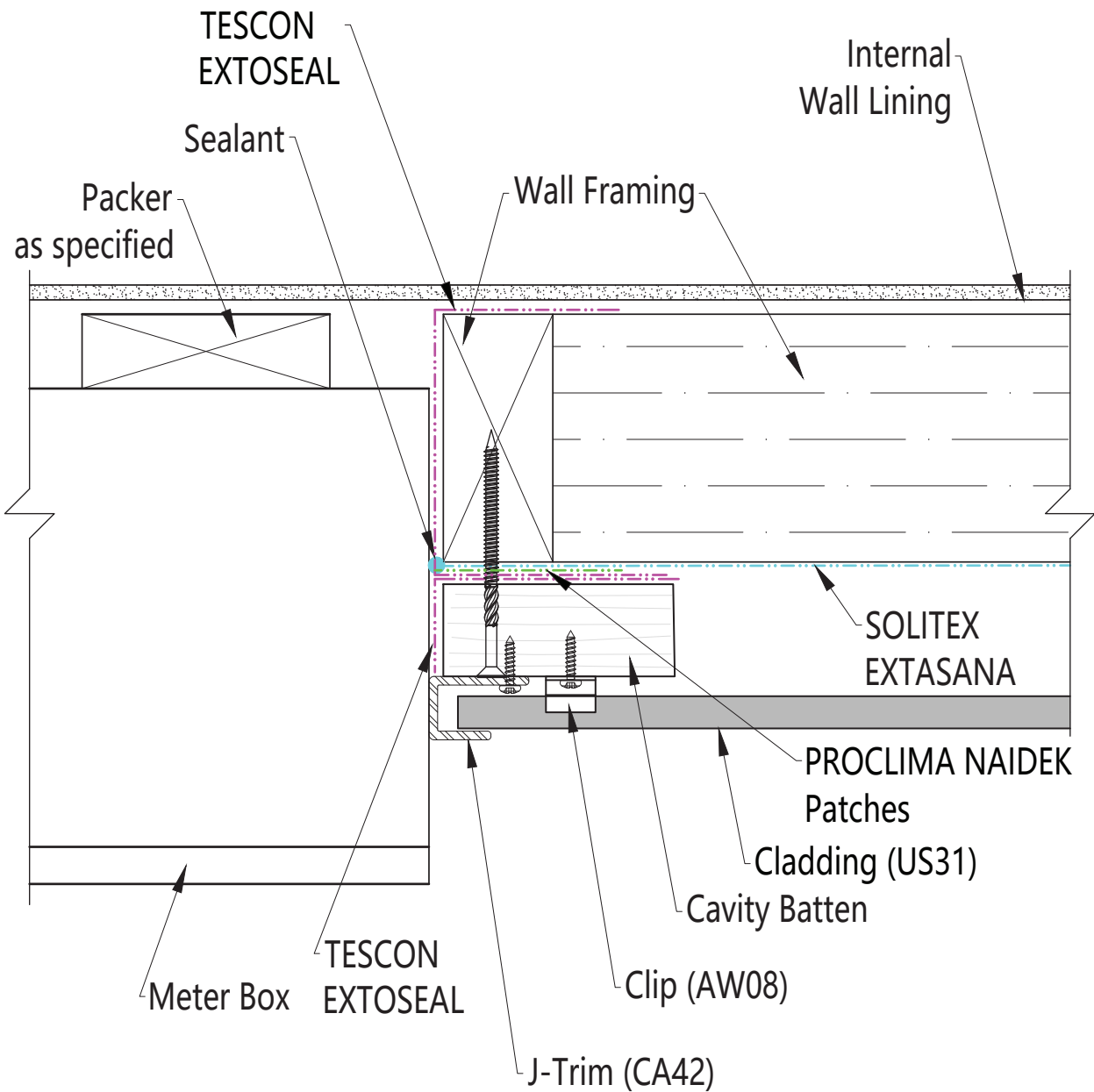

5.1.10 Meter Box Sill

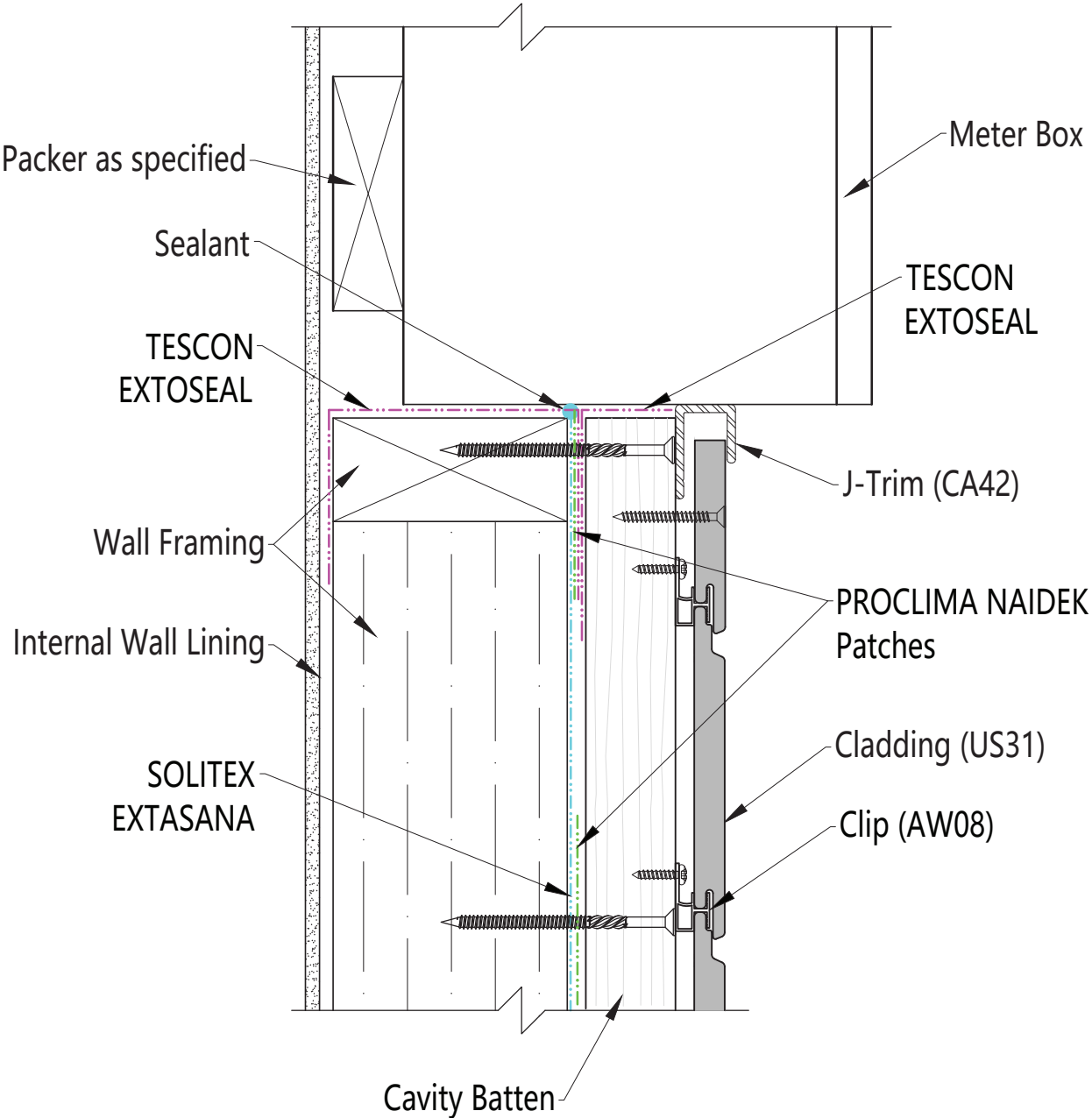

5.1.11 Window Head

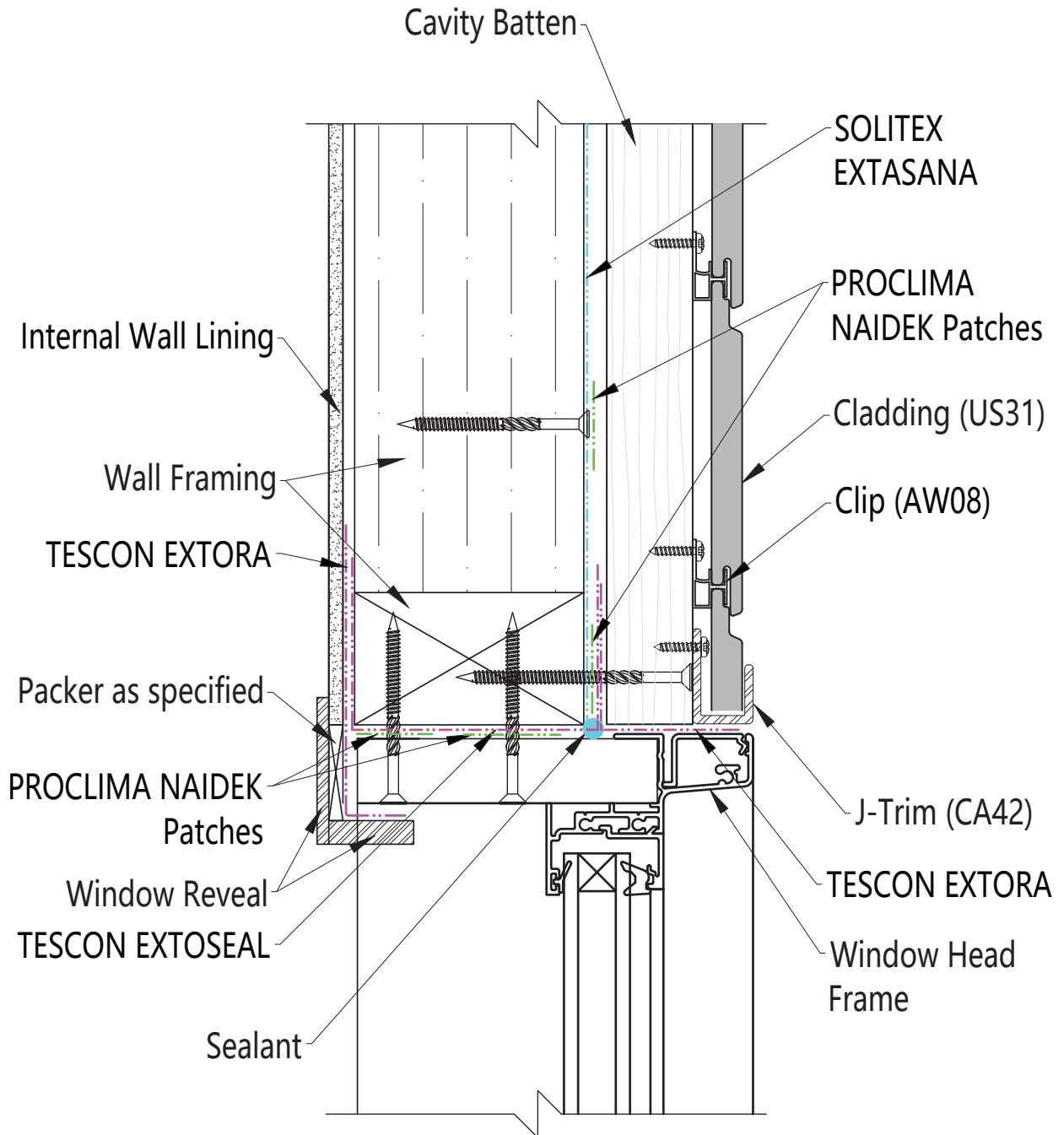



5.1.12 Window Jamb

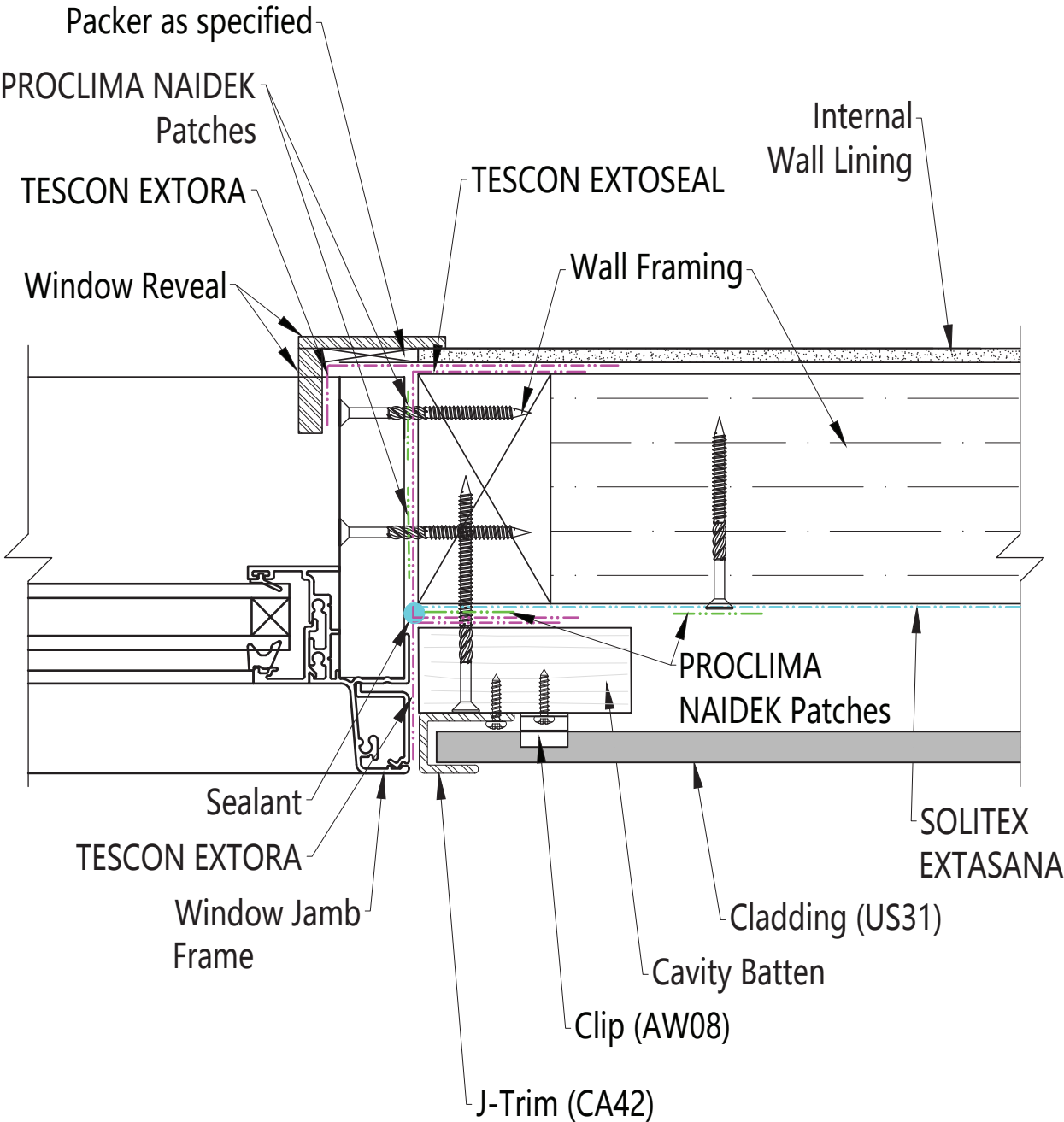

5.1.13 Window Sill

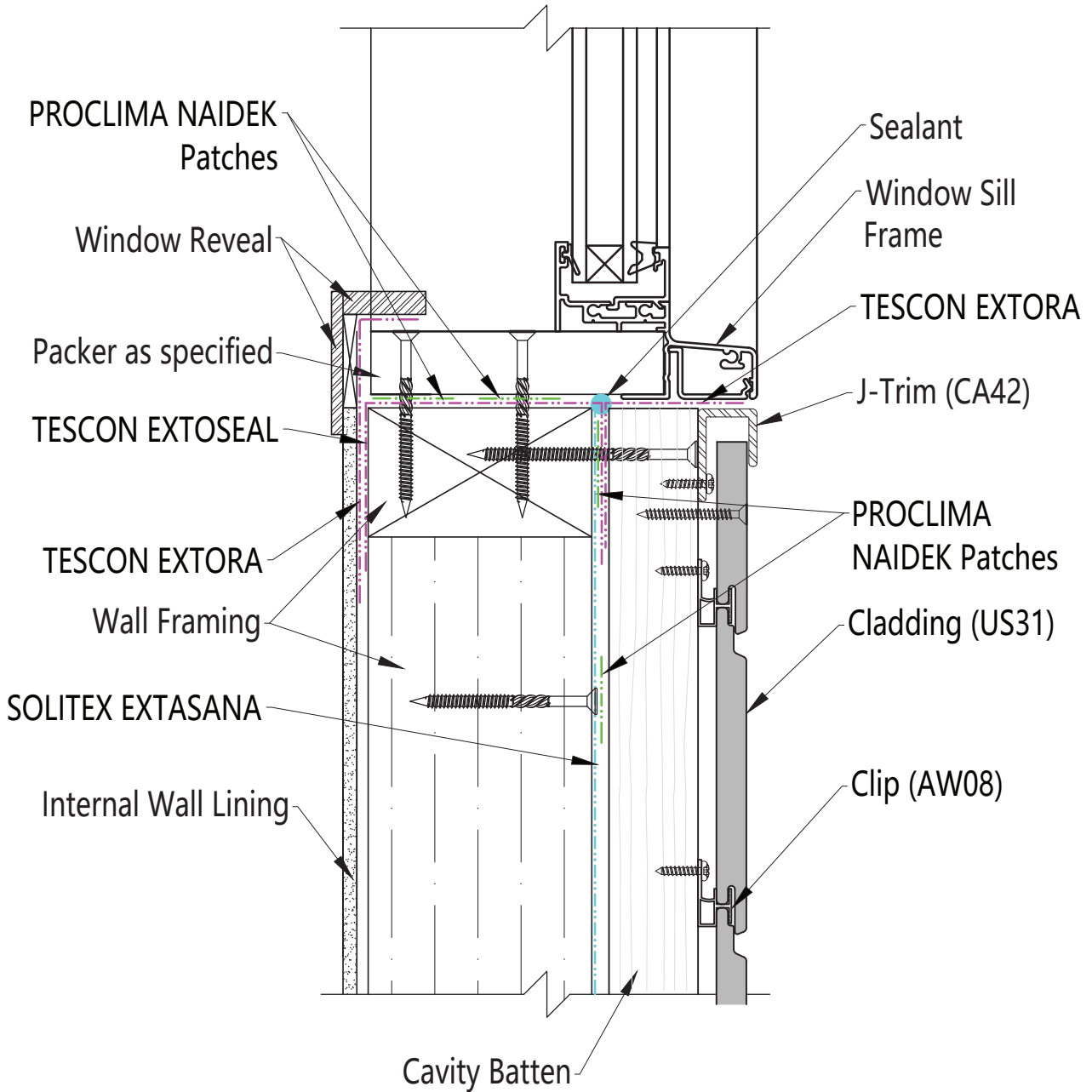

5.1.14 Pipe Penetration

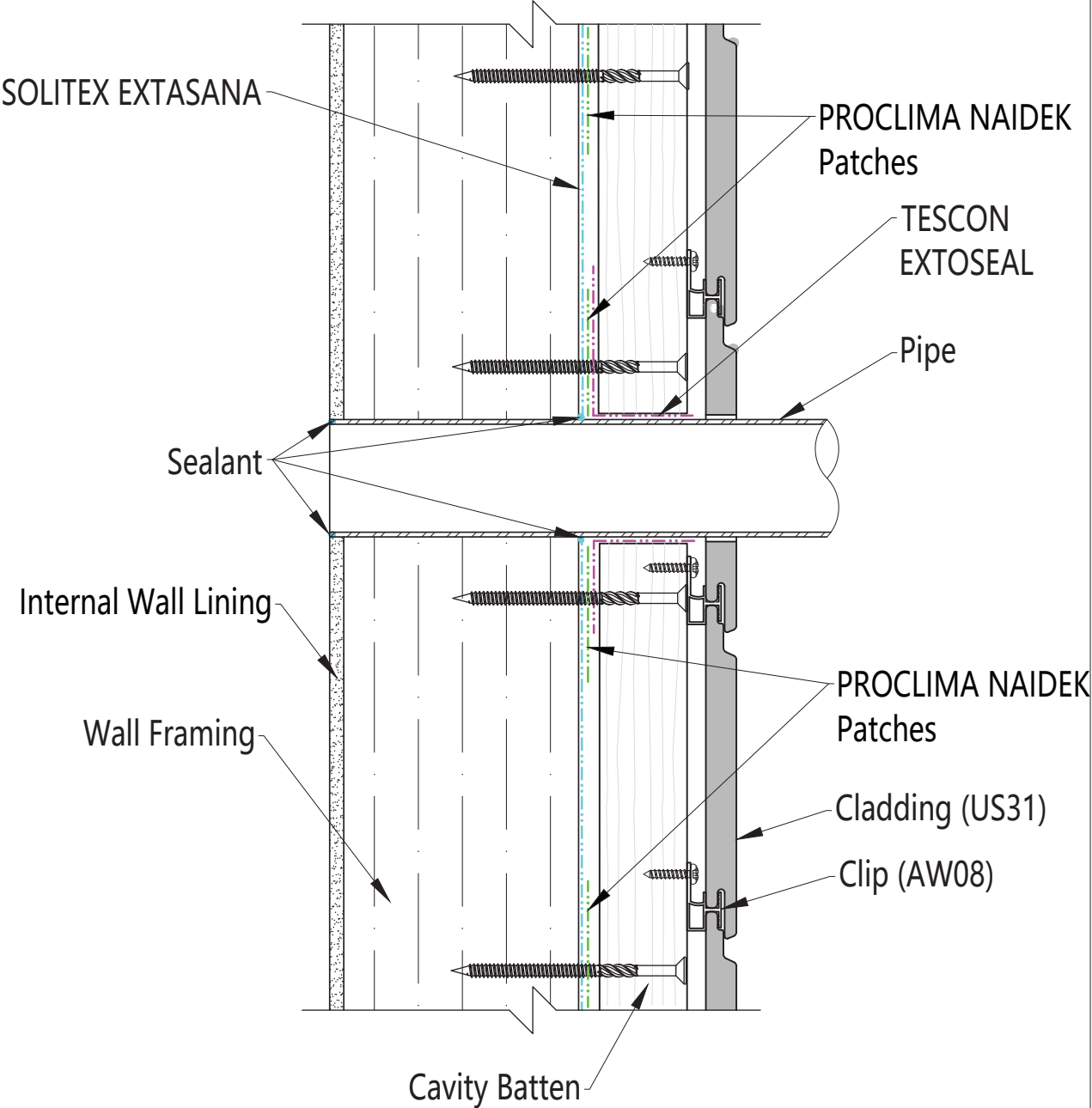

5.115 Eave Soffit

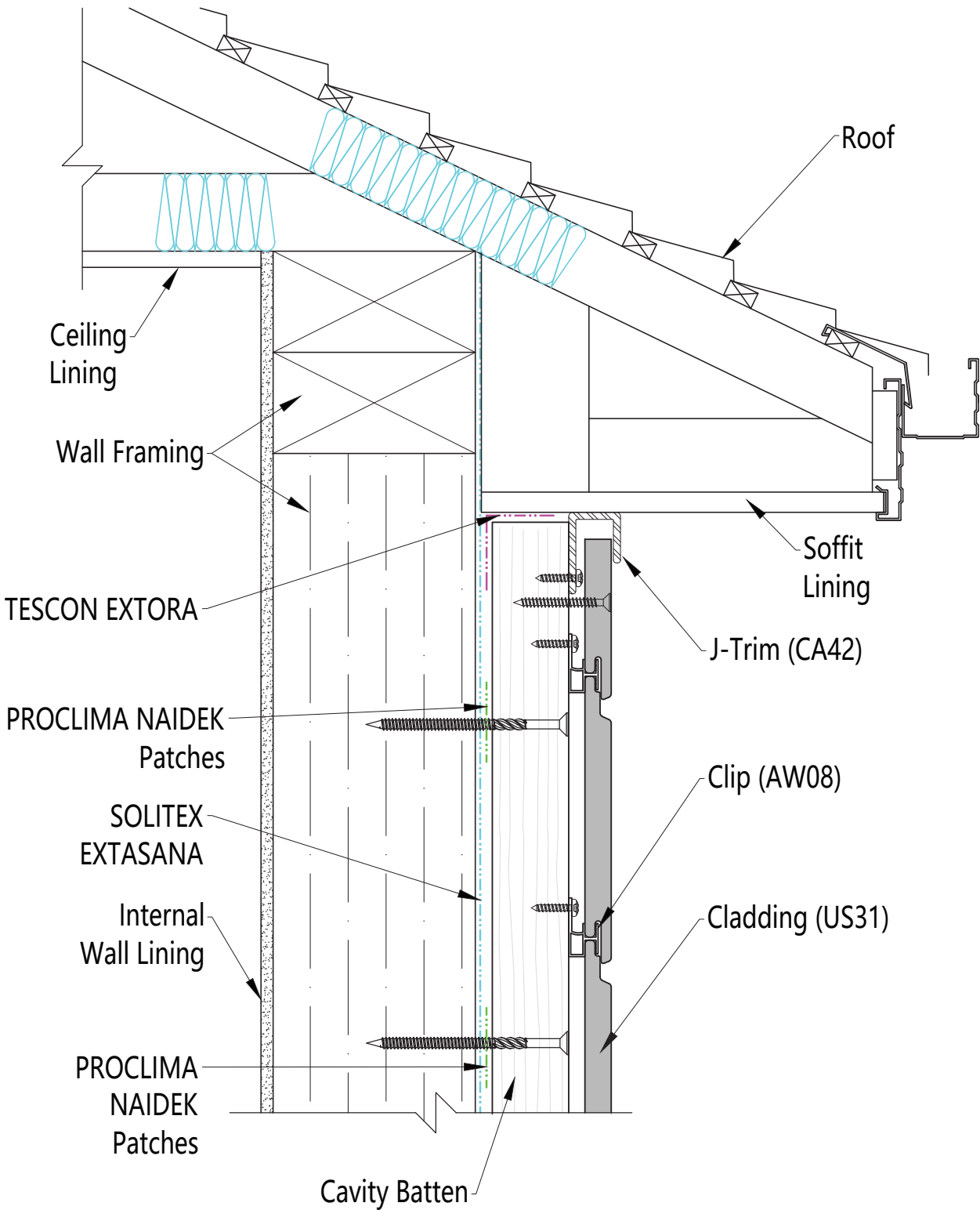

5.1.16 Garage / Bulkhead / Overhang / Drip

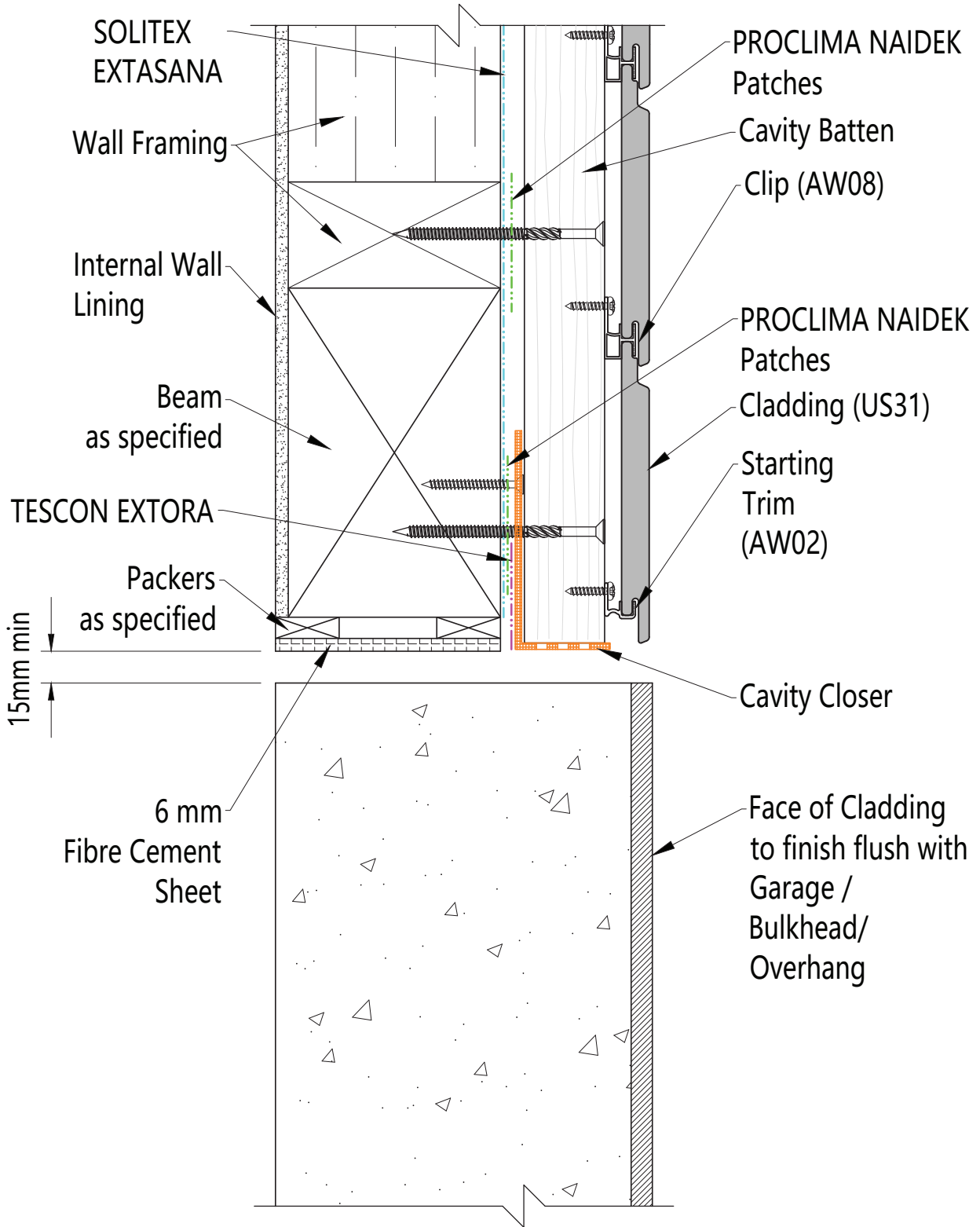

5.1.17 Metal Capping Parapet Wall to Box Gutter

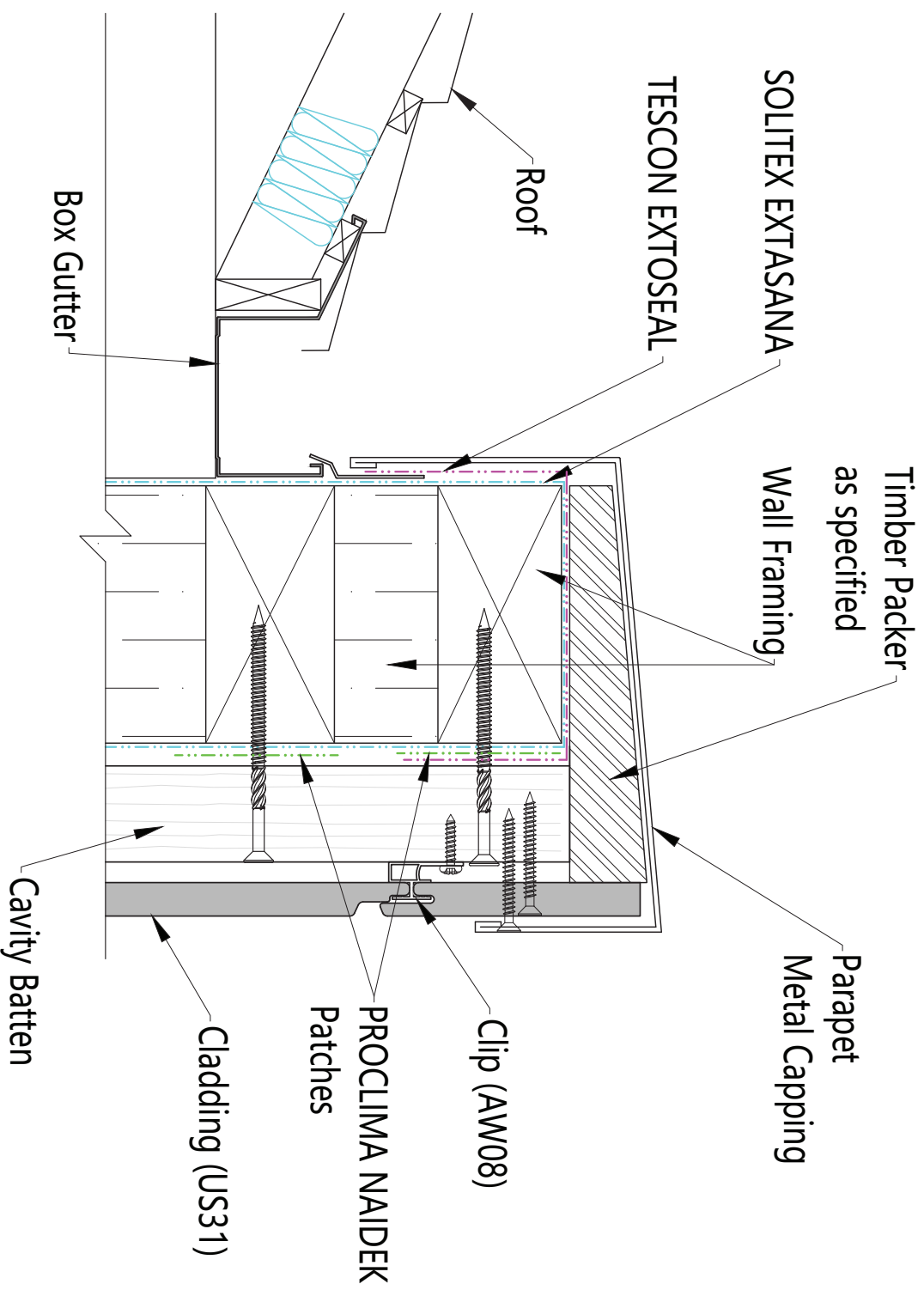

5.1.18 Metal Capping Parapet Wall to Roof

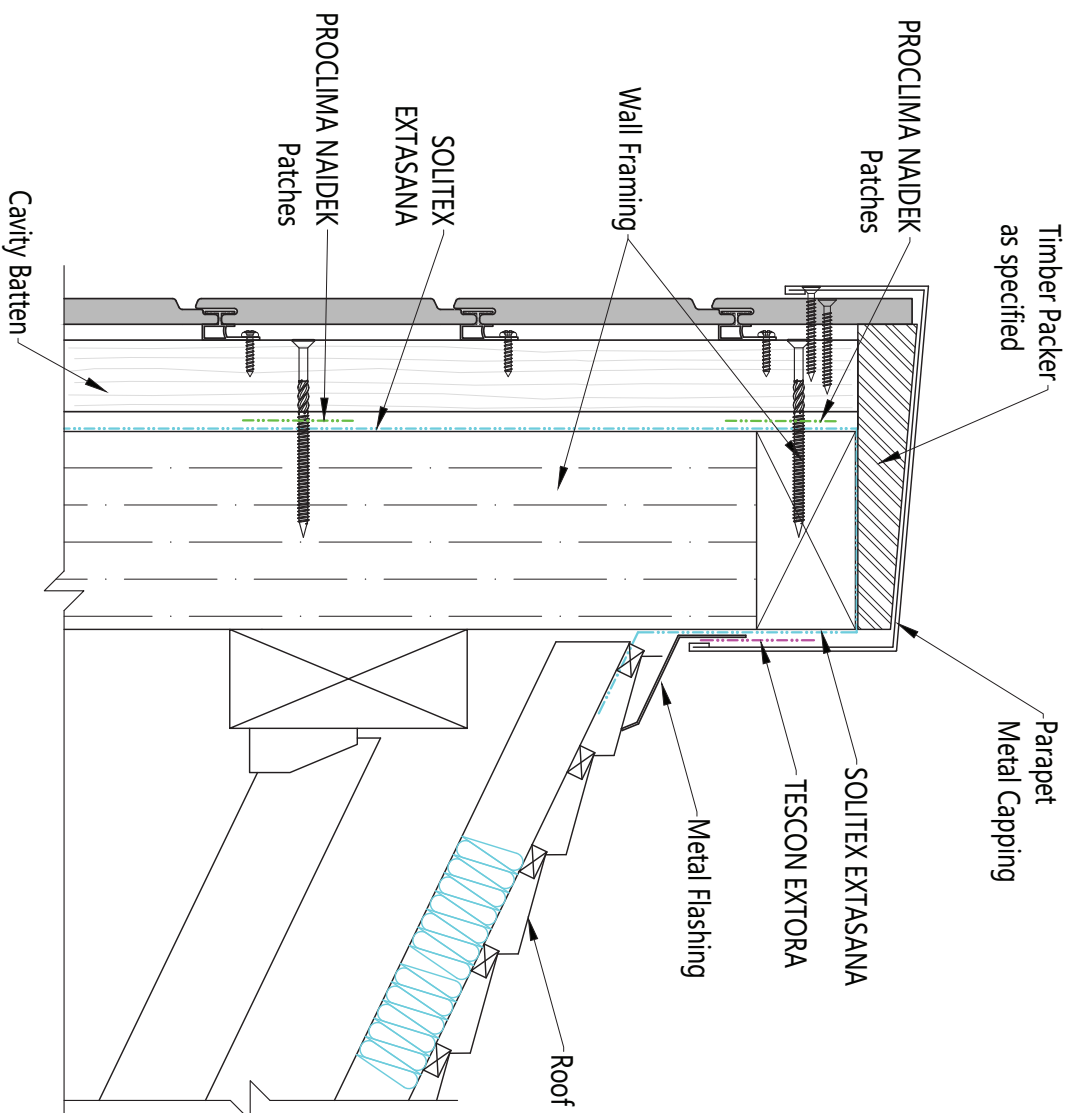

5.1.19 Outside Corner

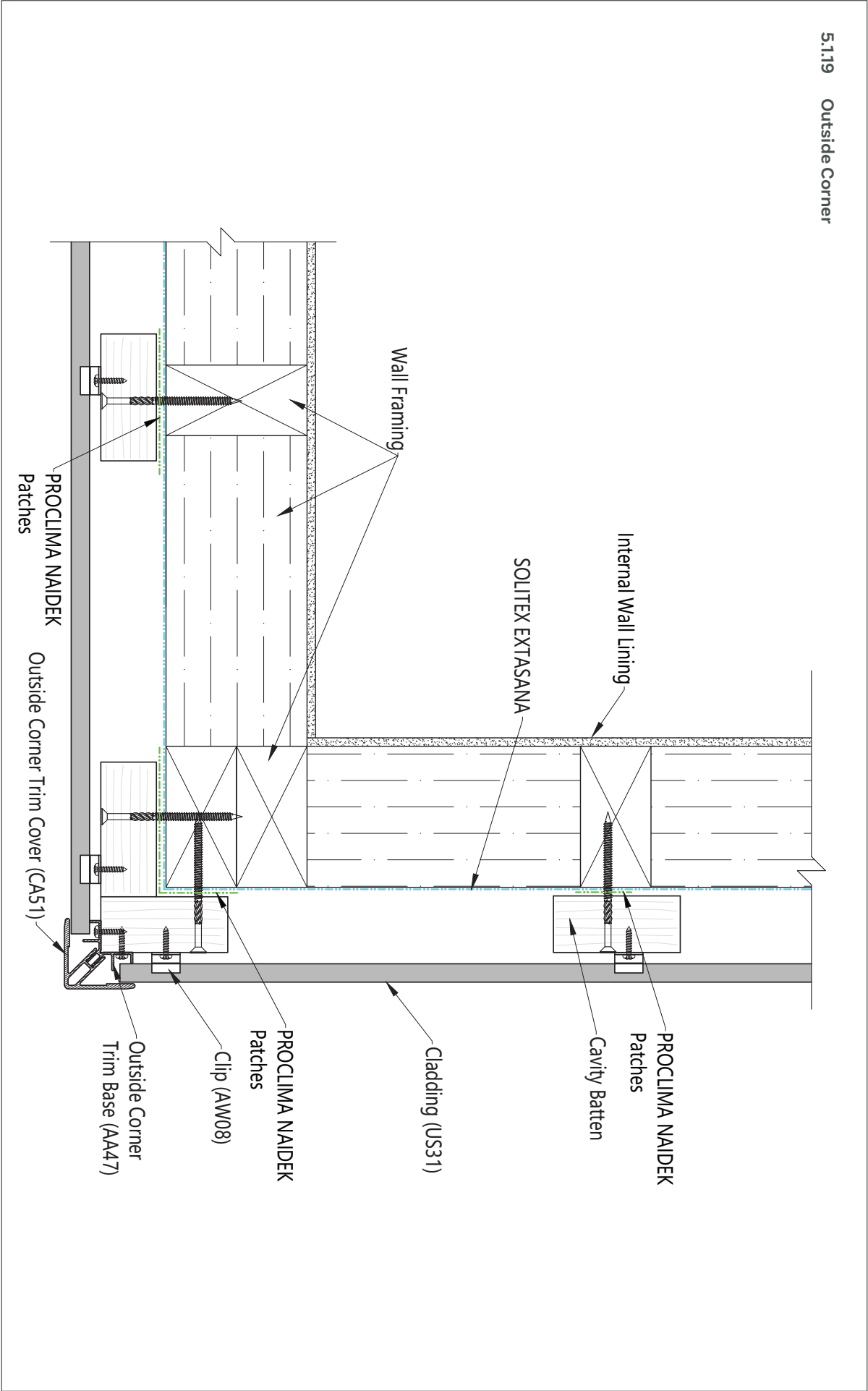



5.1.20 Inside Corner

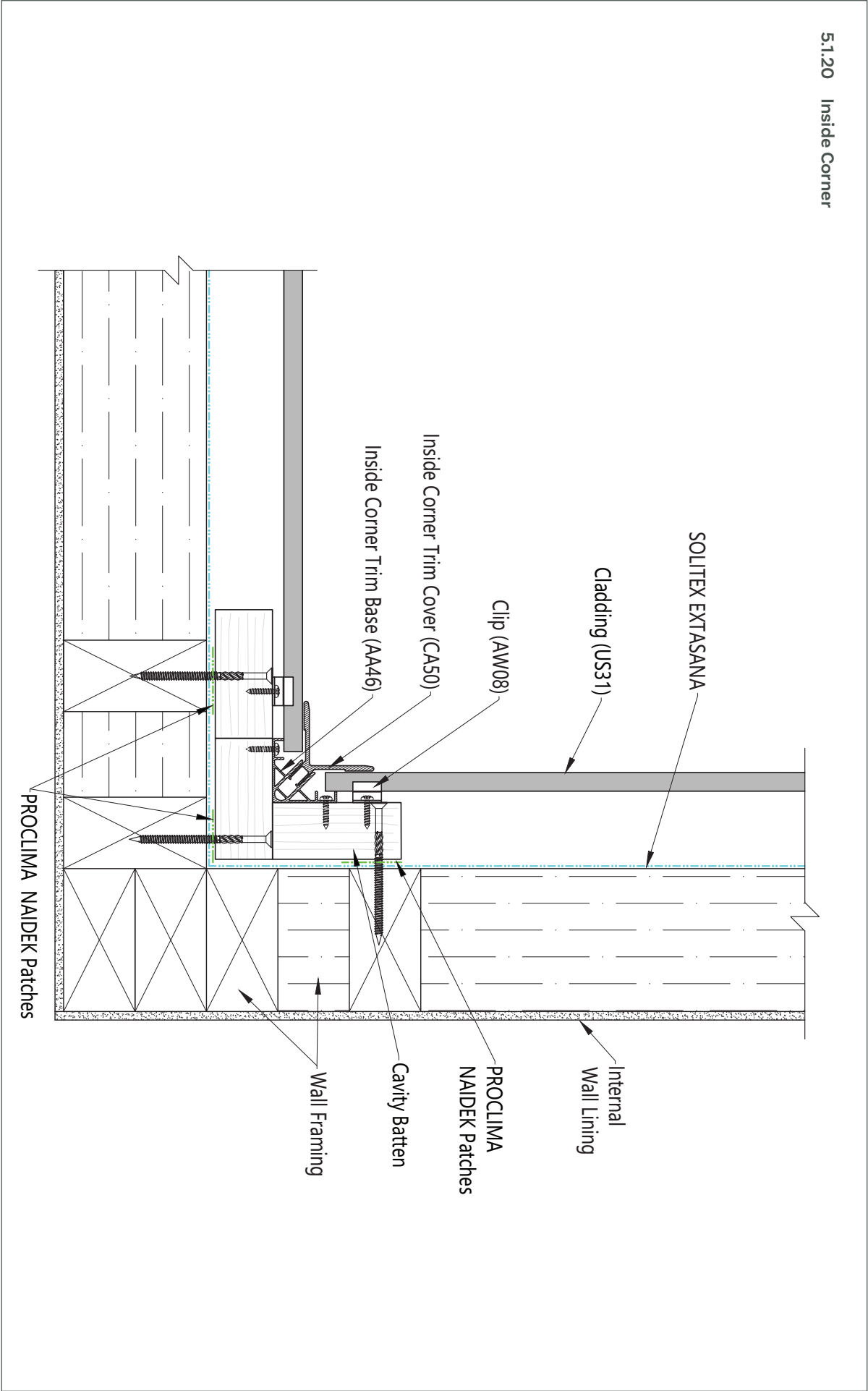

5.1.21 Wall Over Roof

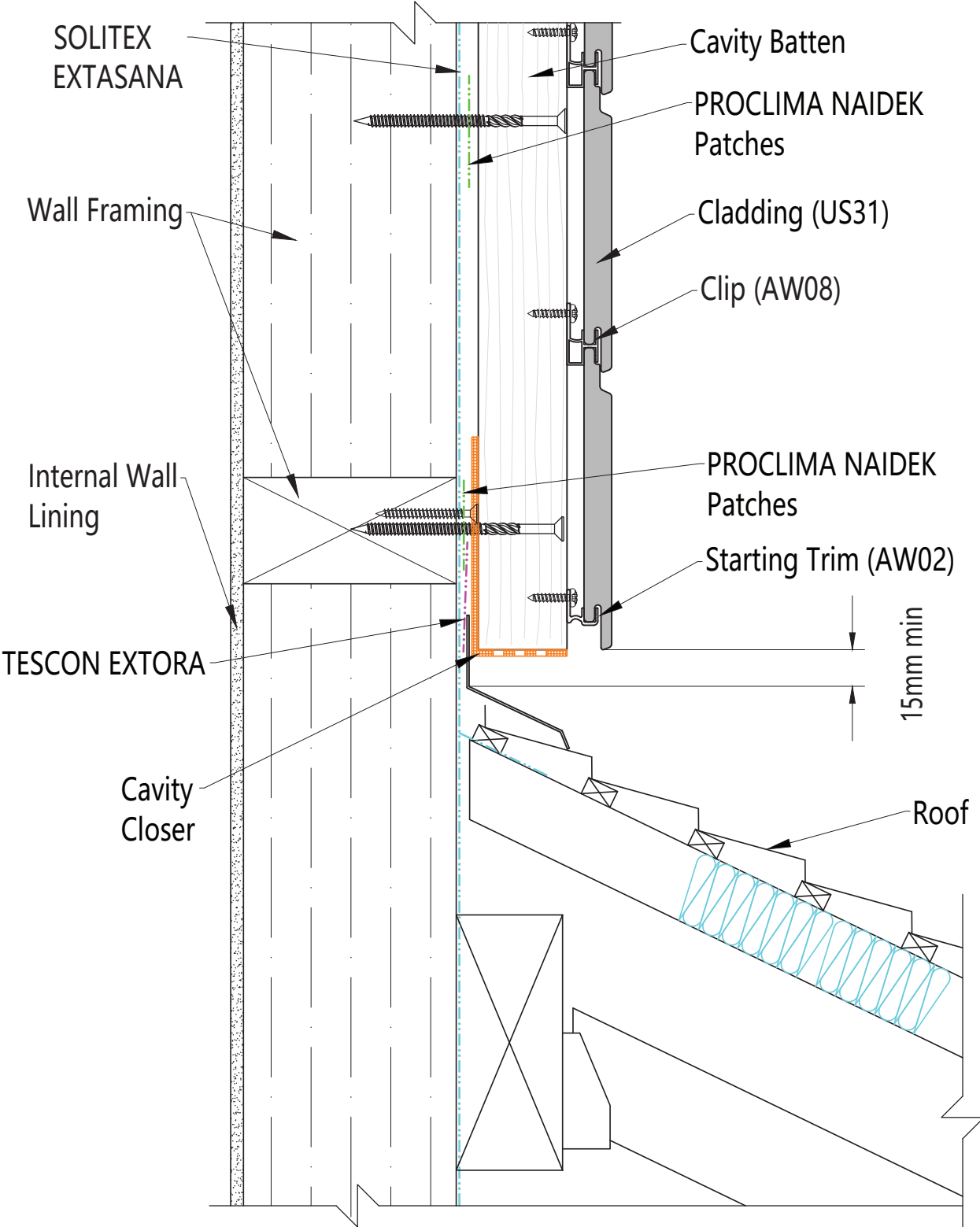

5.1.22 Outermost Edge

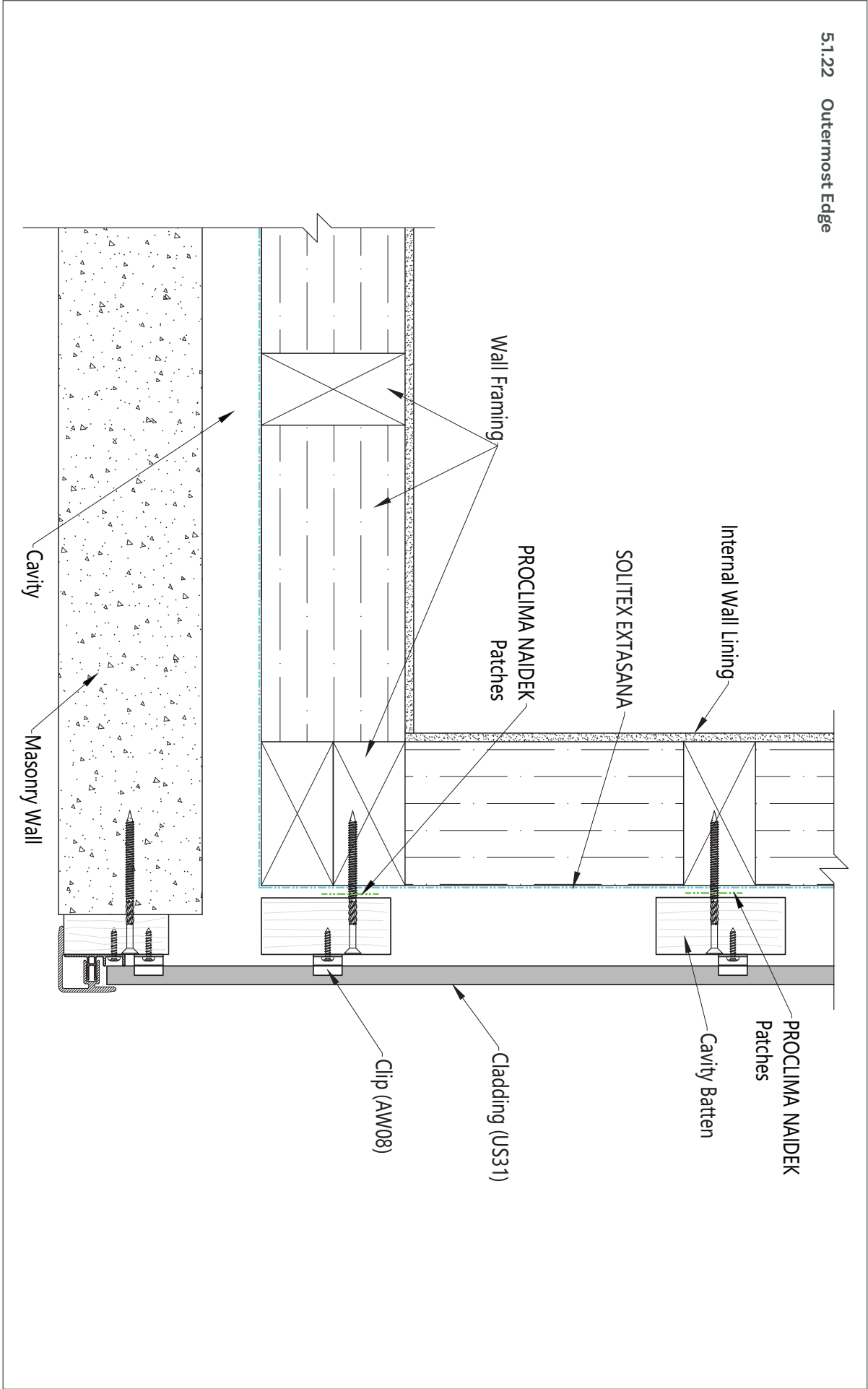

5.2 Vertical Shadowline Boards

5.2.1 Concrete Slab Edge

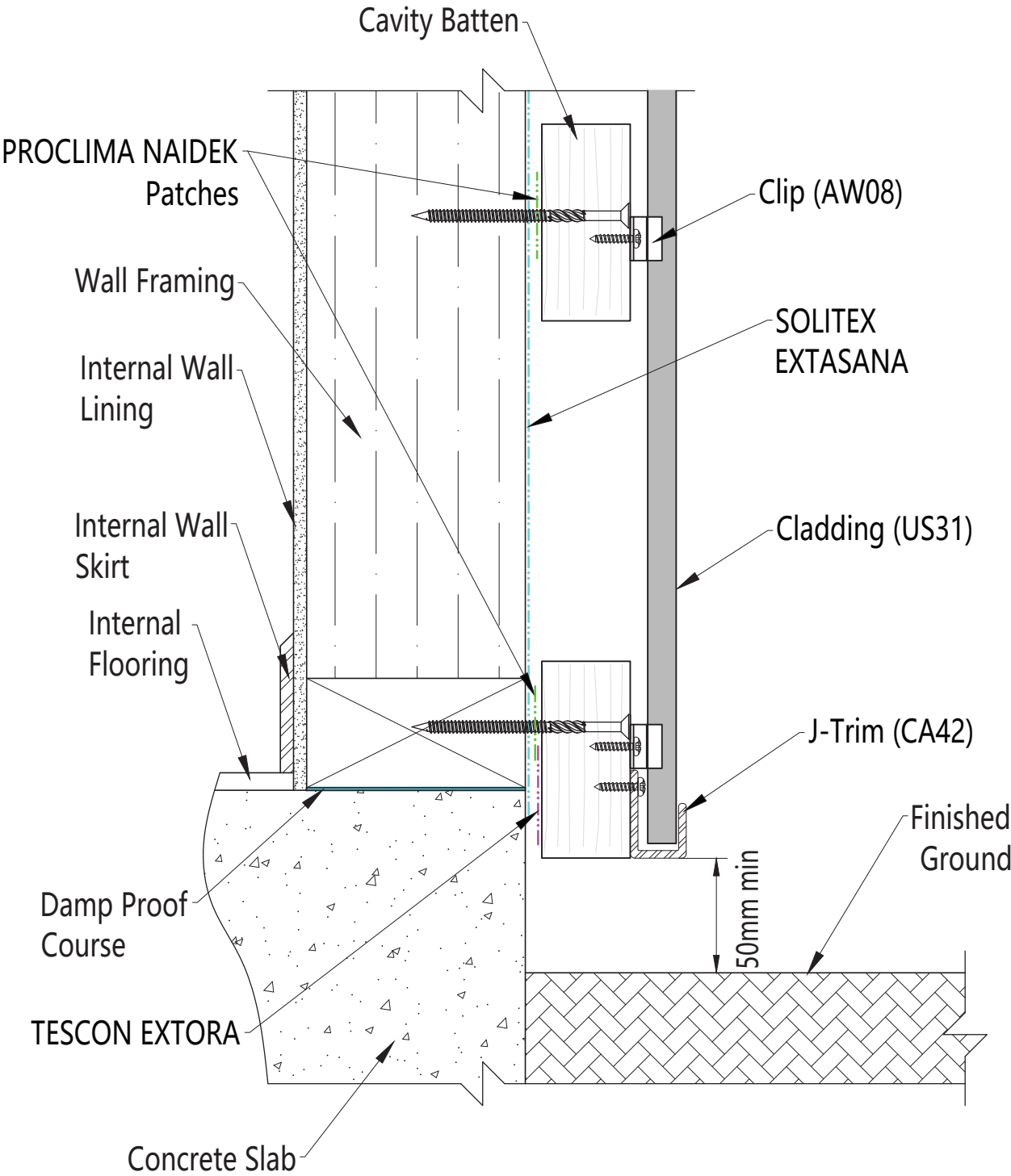

5.2.2 Concrete Slab Rebate

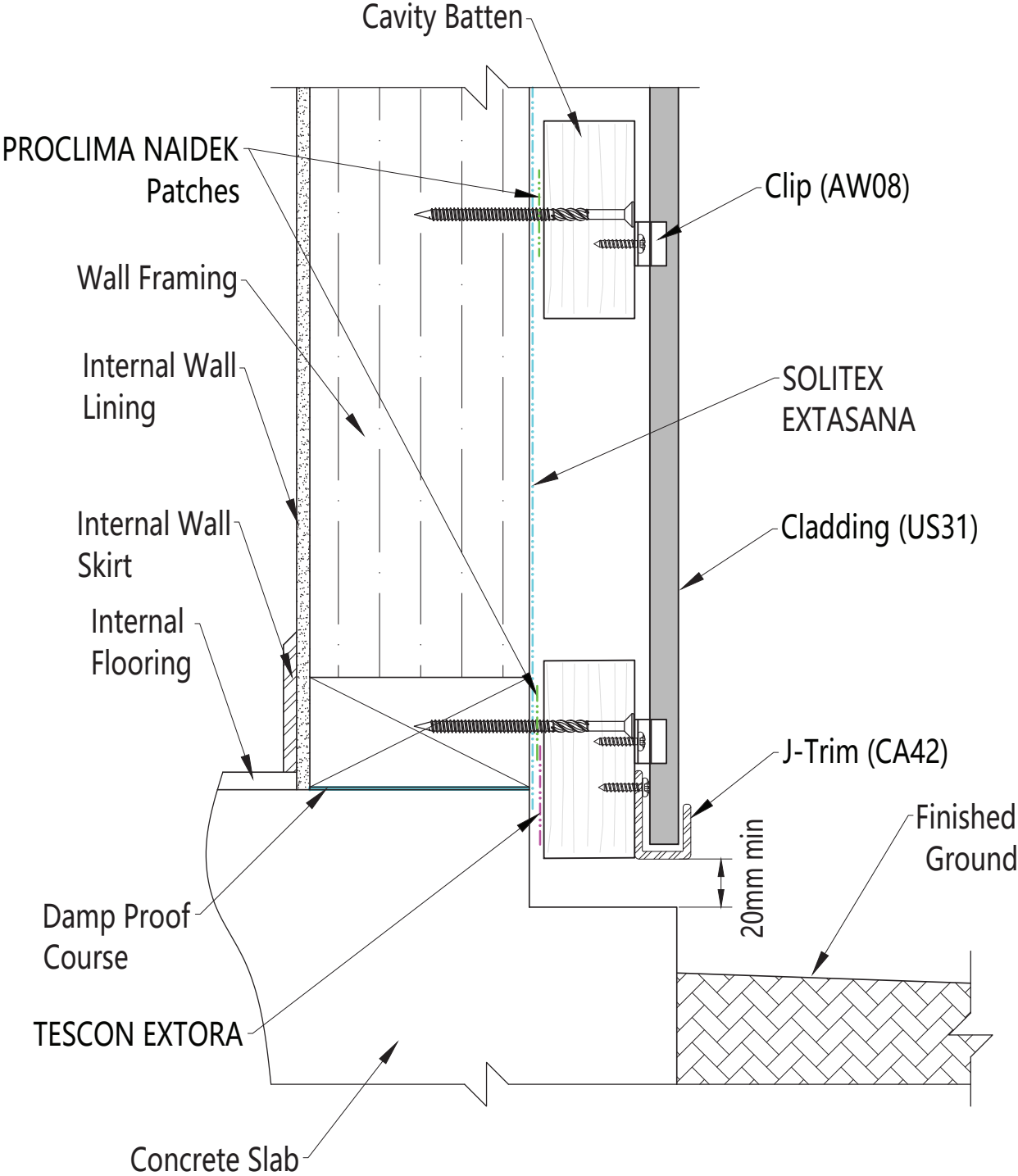

### 5.2.3 Downpipe Fixing

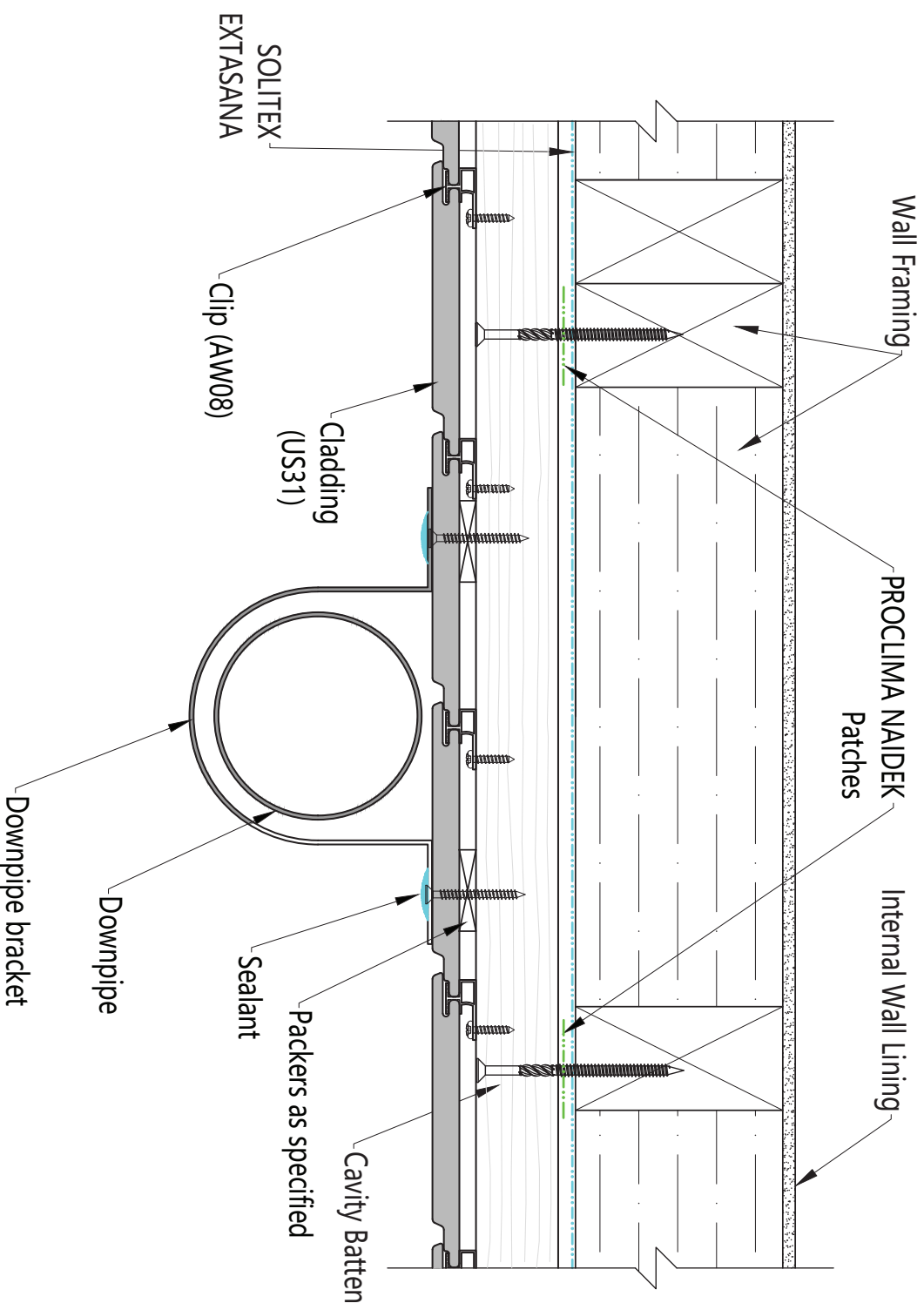

5.2.4 Wall to Balcony

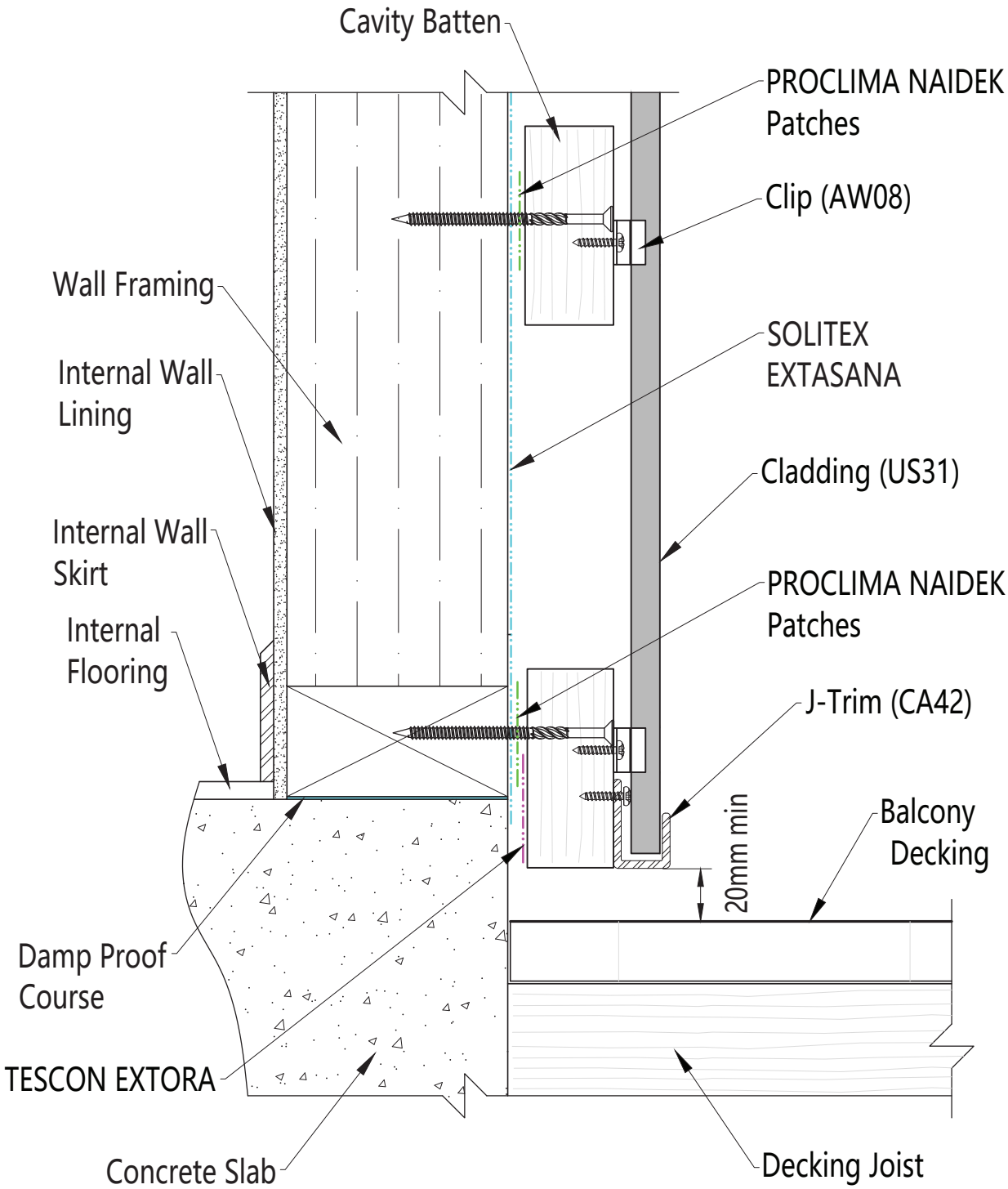

5.2.5 Panels Over Masonry Wall

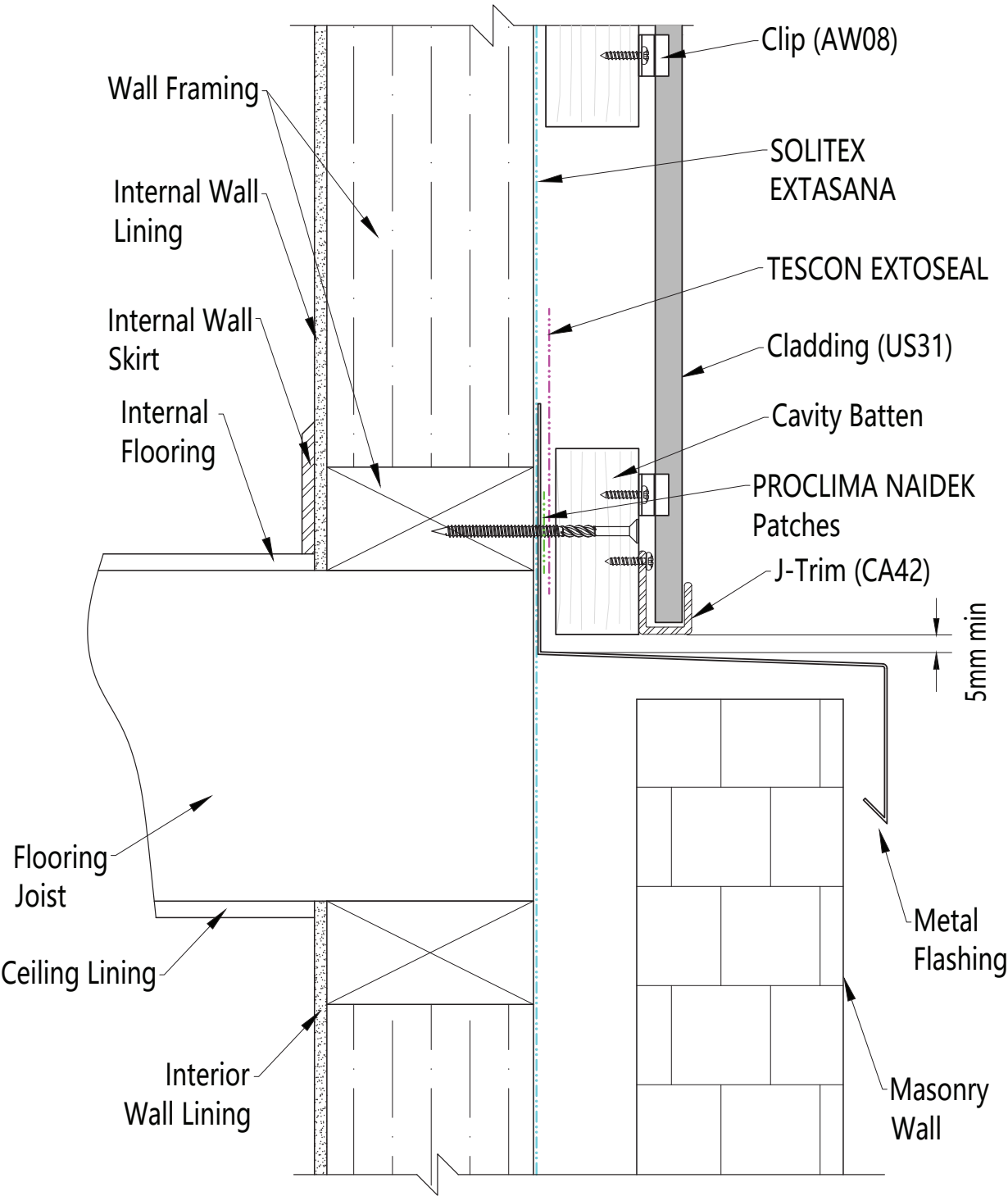



5.2.6 Horizontal Expansion Joint

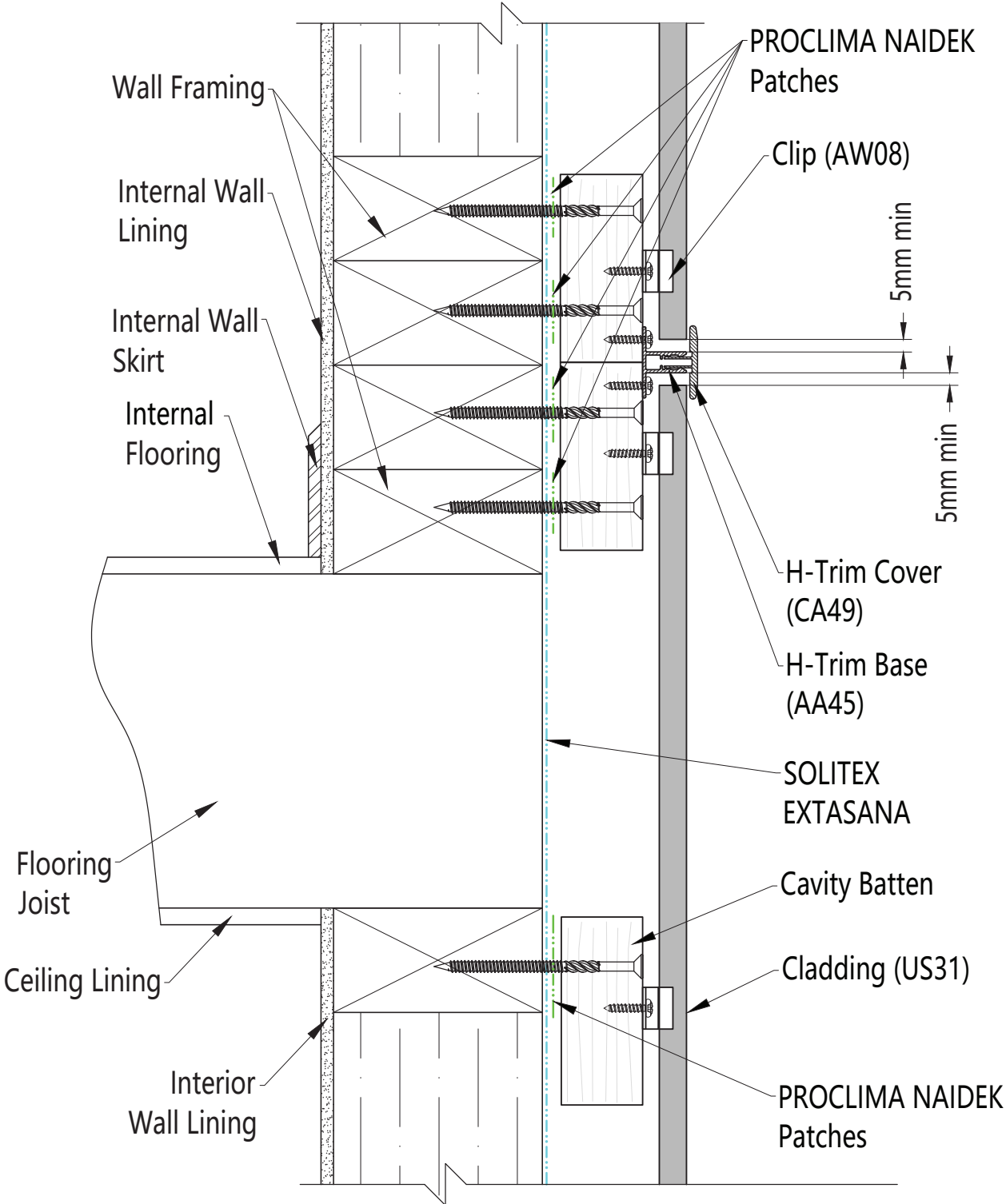

5.2.7 Vertical Expansion Joint

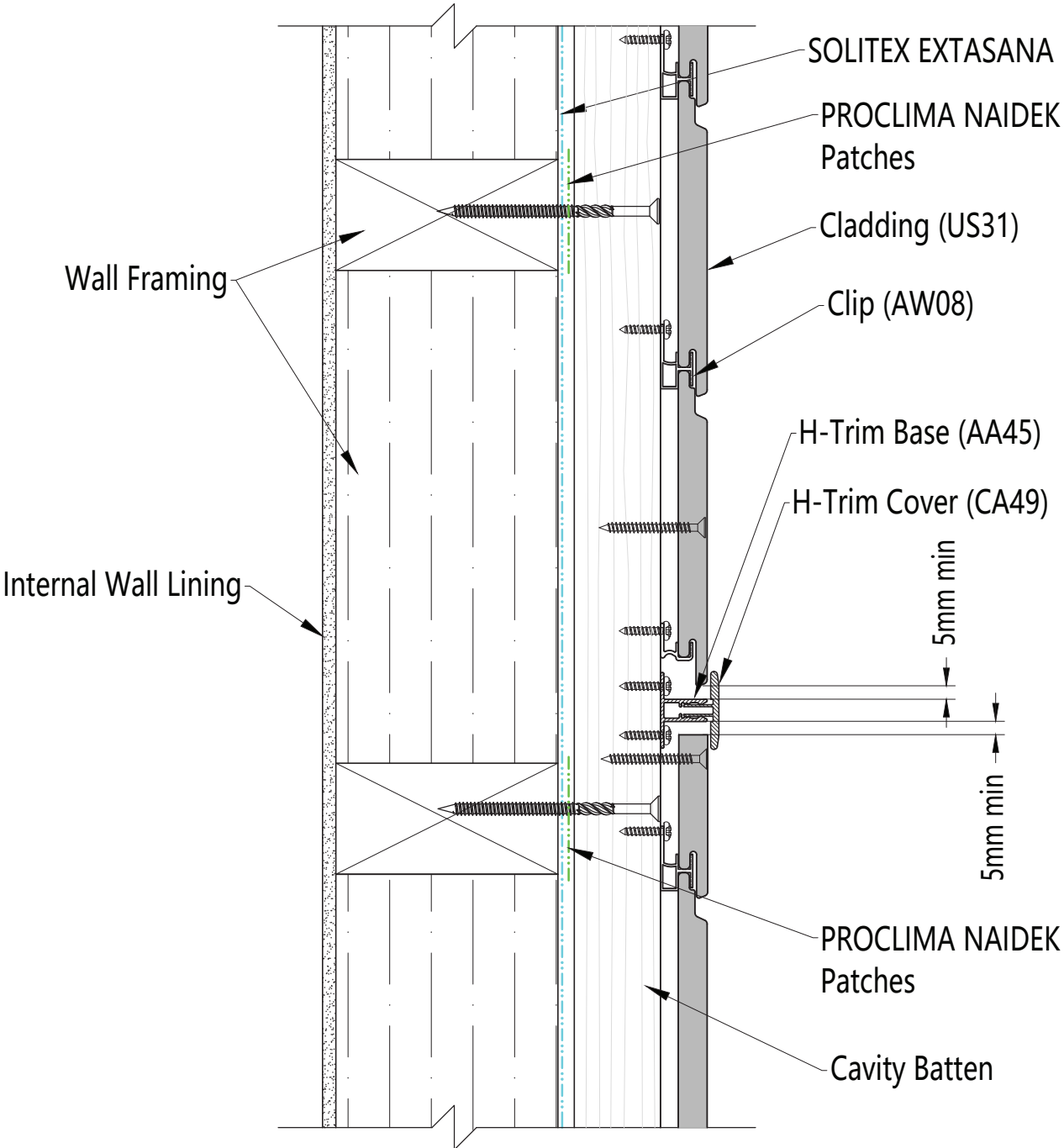

5.2.8 Meter Box Head

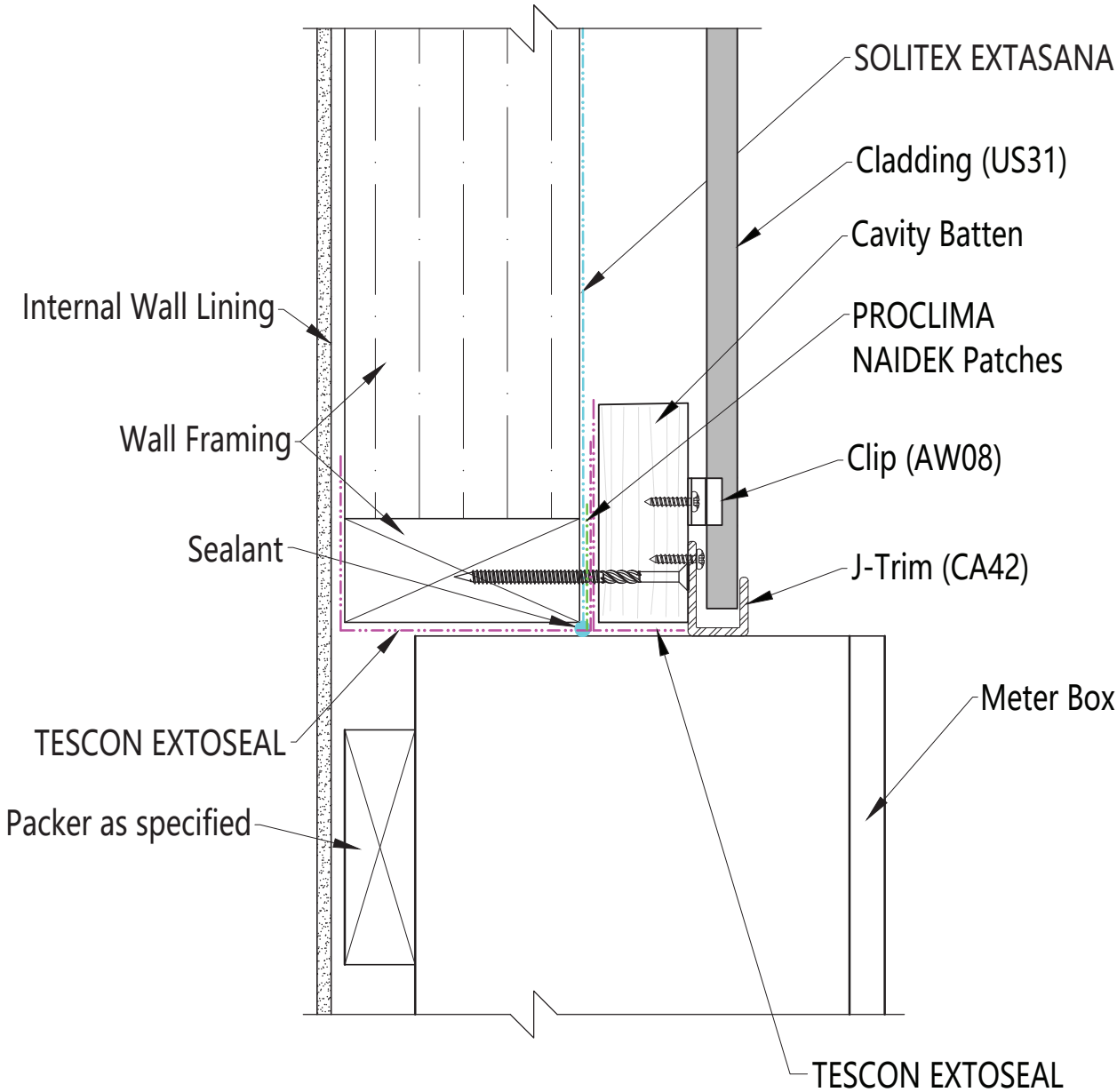

5.2.9 Meter Box Jamb

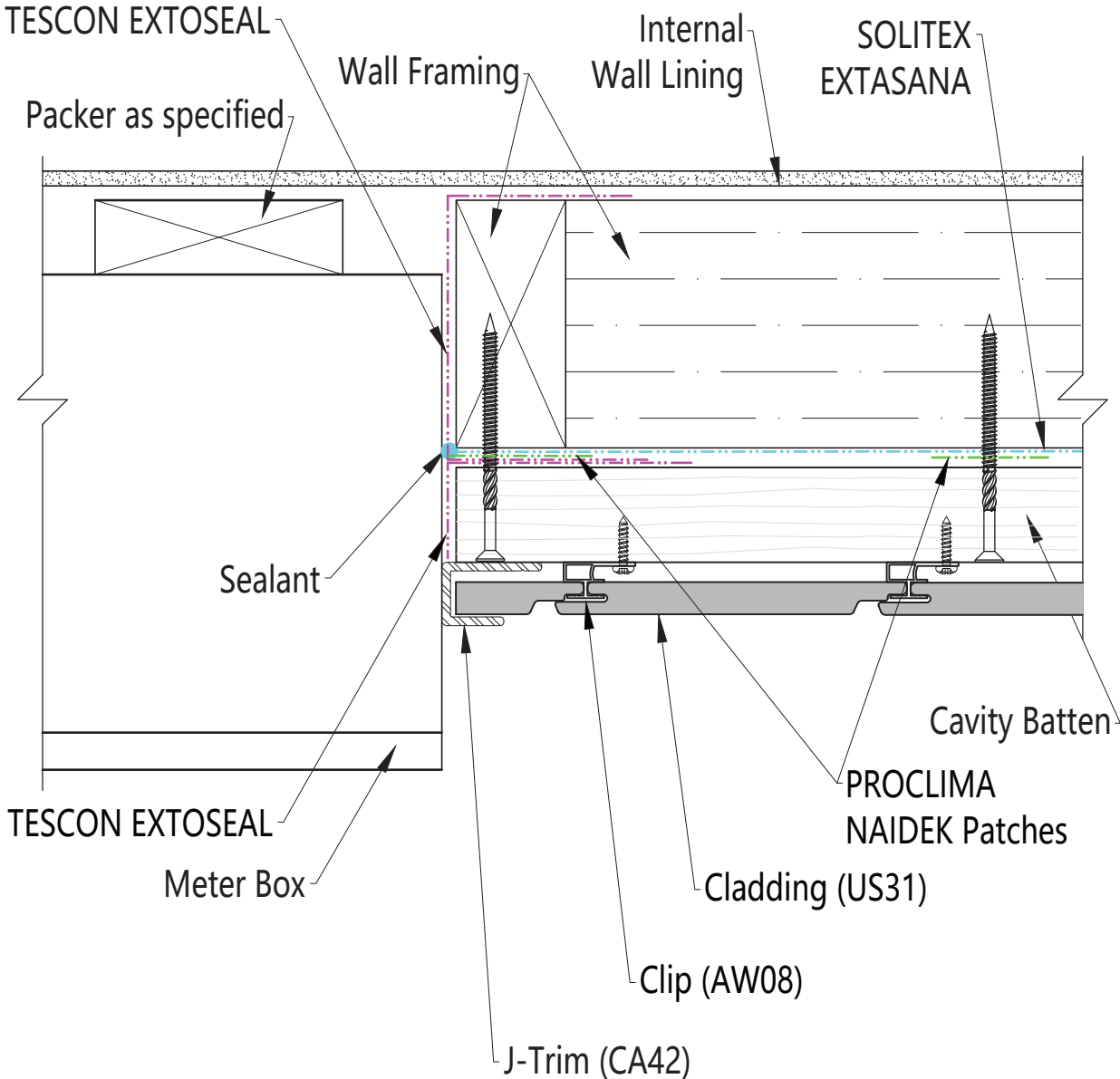

5.2.10 Meter Box Sill

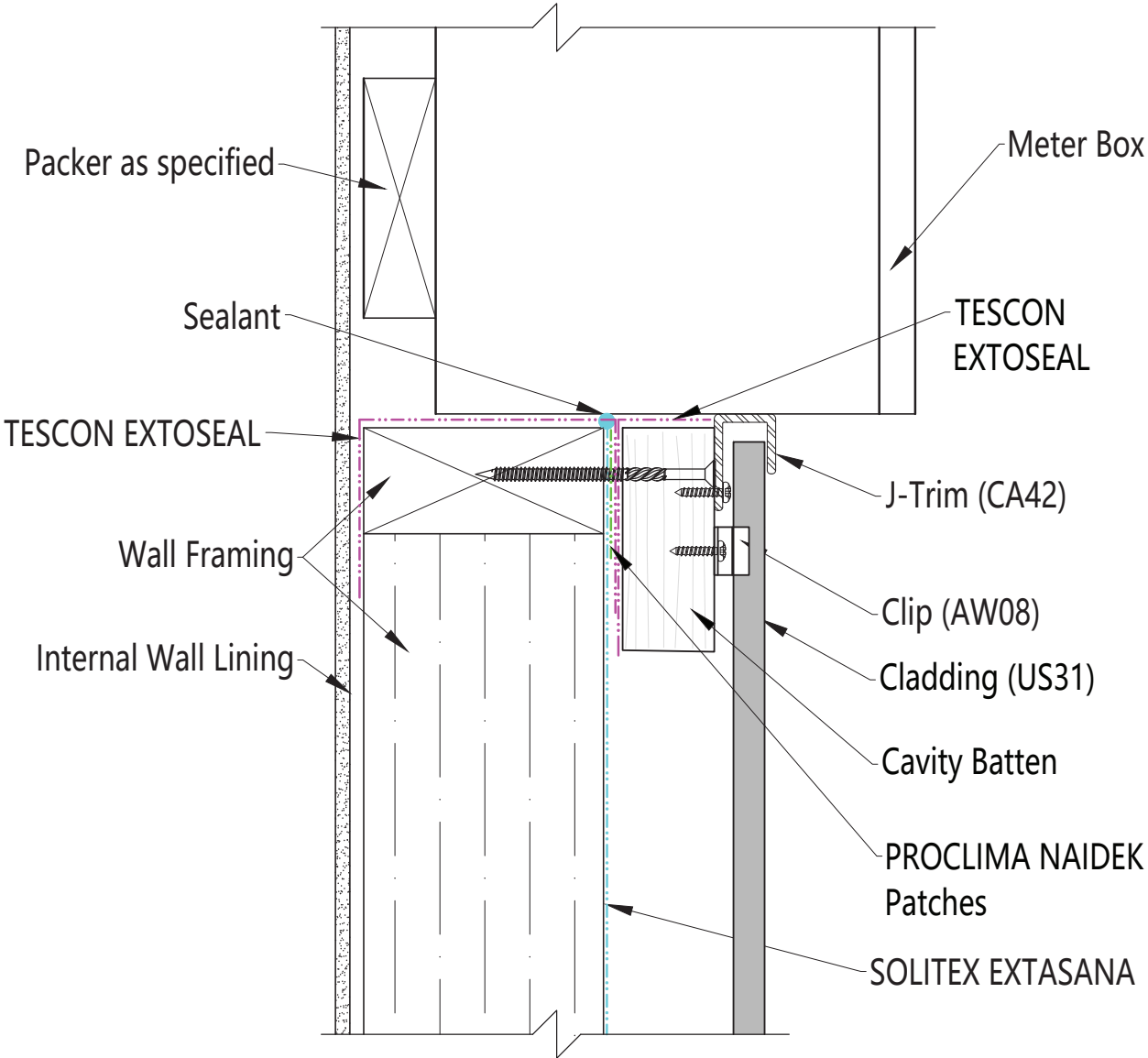

5.2.11 Window Head

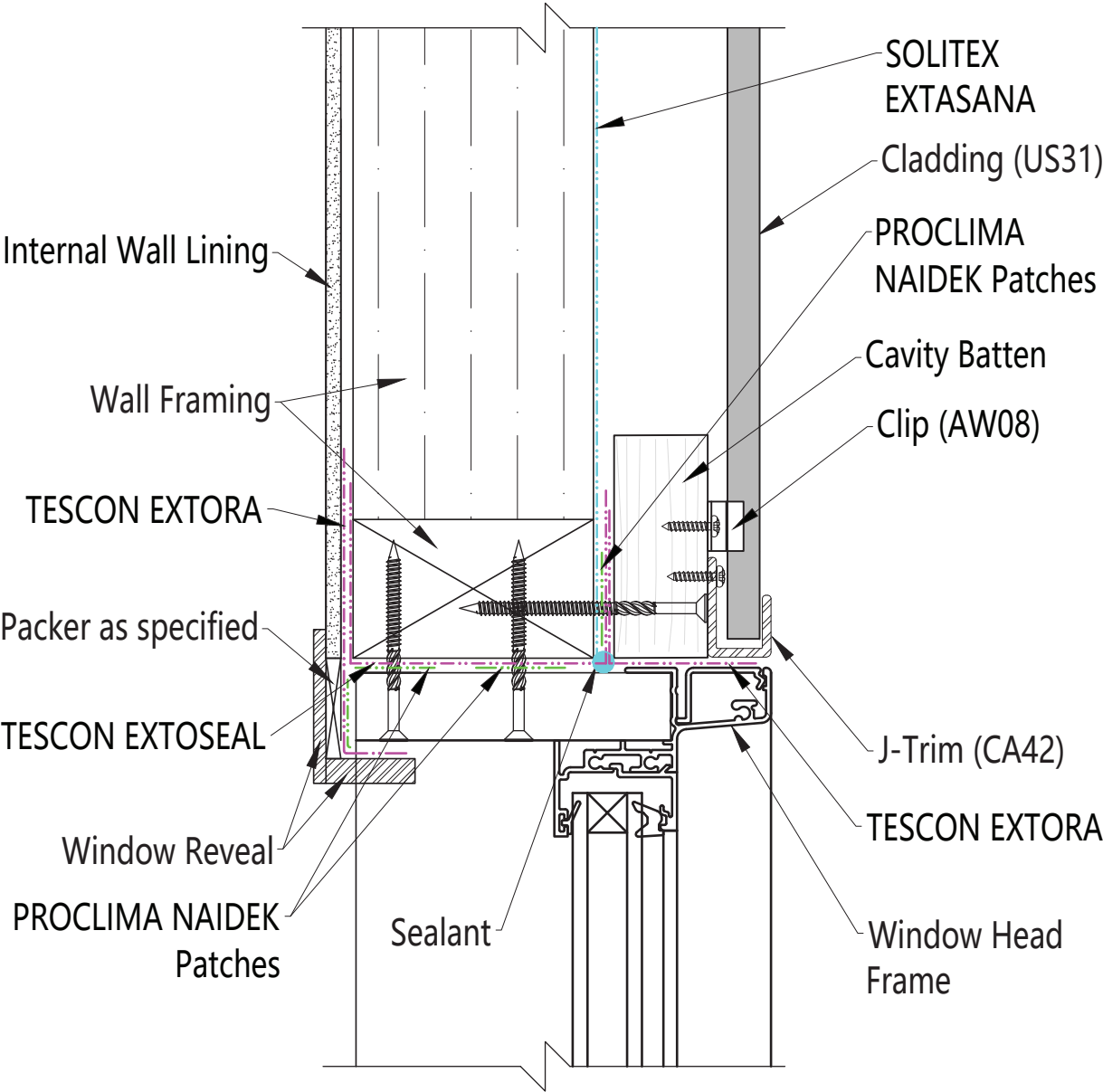

5.2.12 Window Jamb

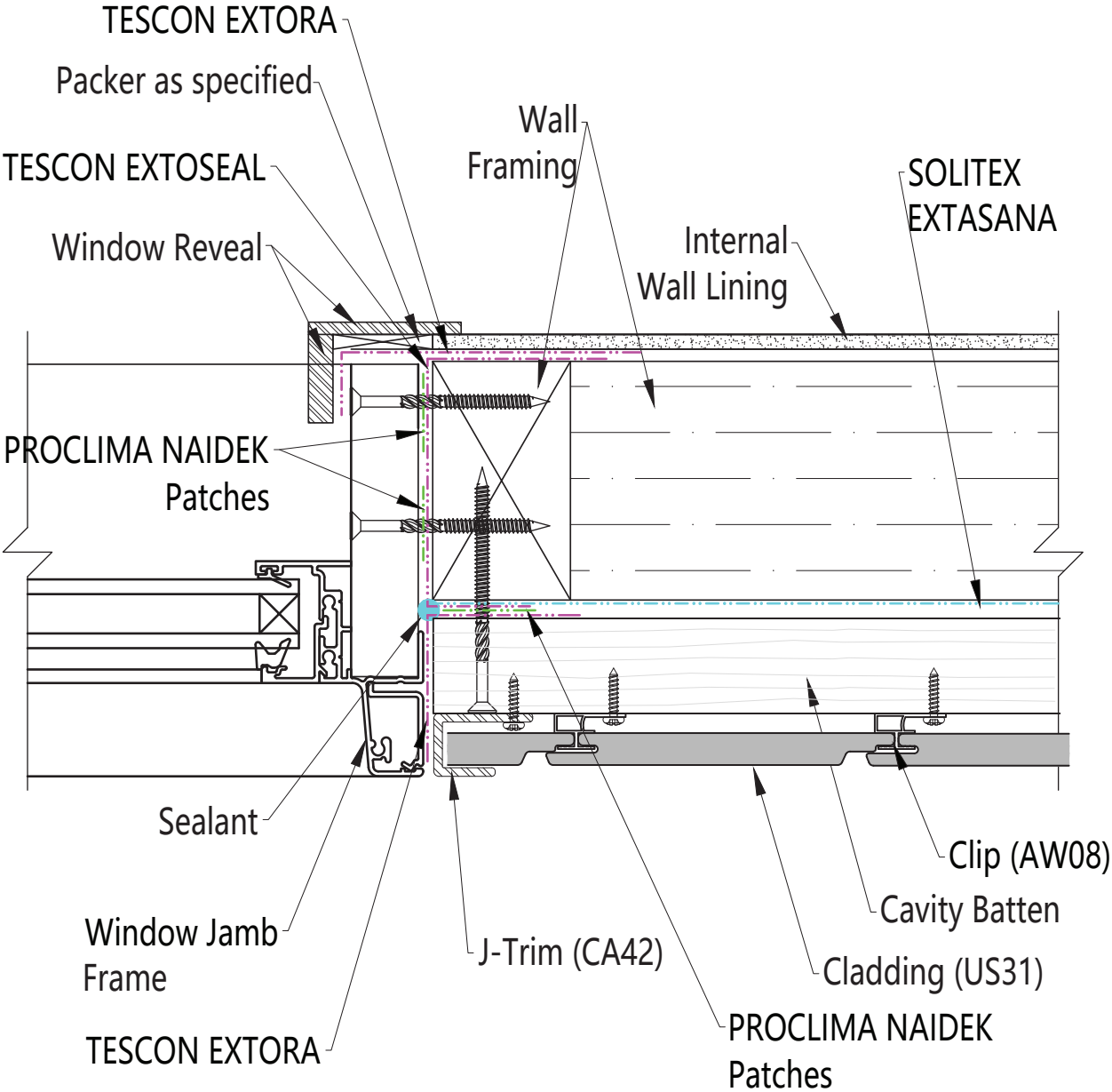

5.2.13 Window Sill

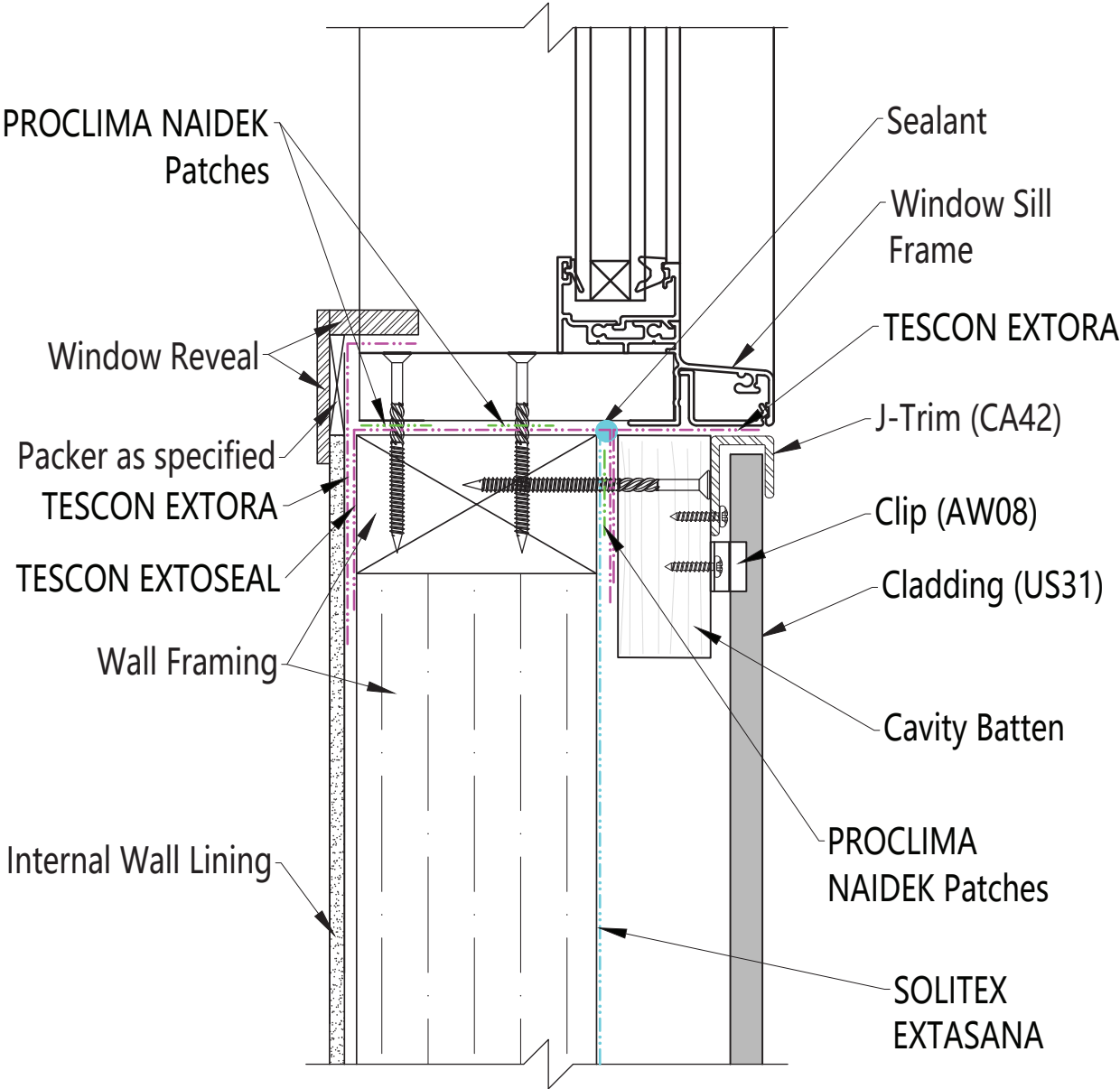



5.2.14 Pipe Penetration

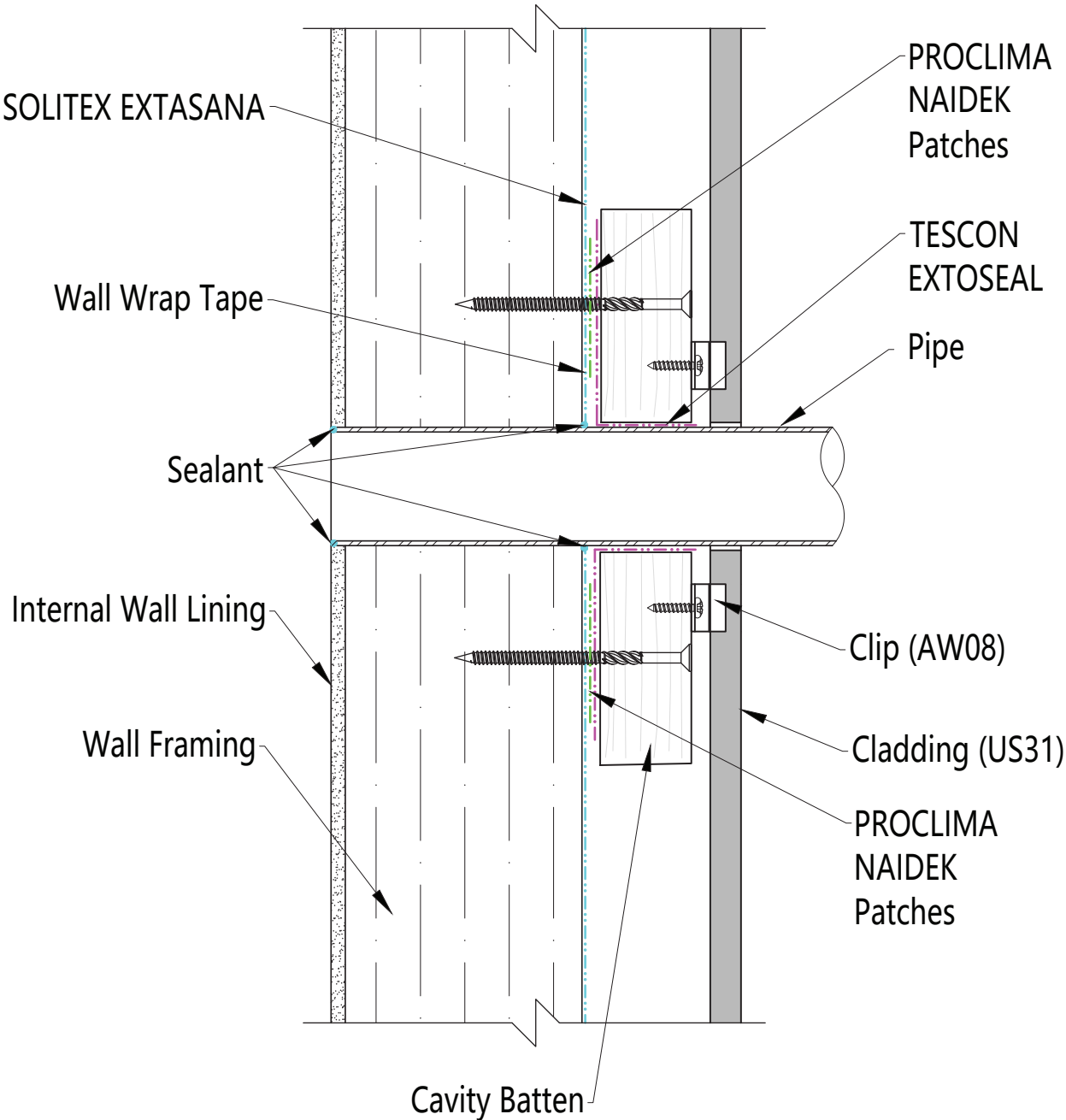

5.2.15 Eave Soffit

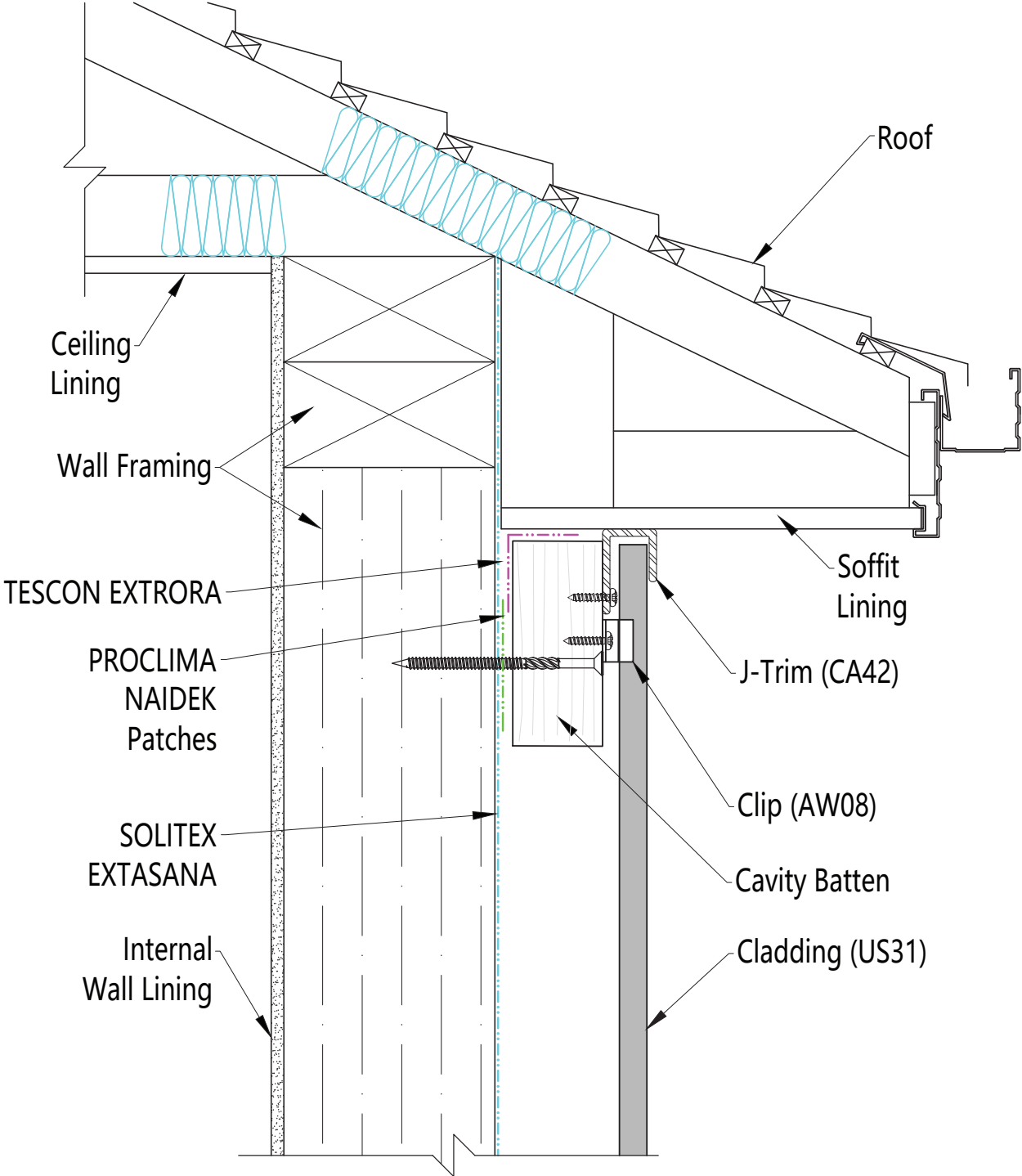

5.2.16 Garage / Bulkhead / Overhang / Drip

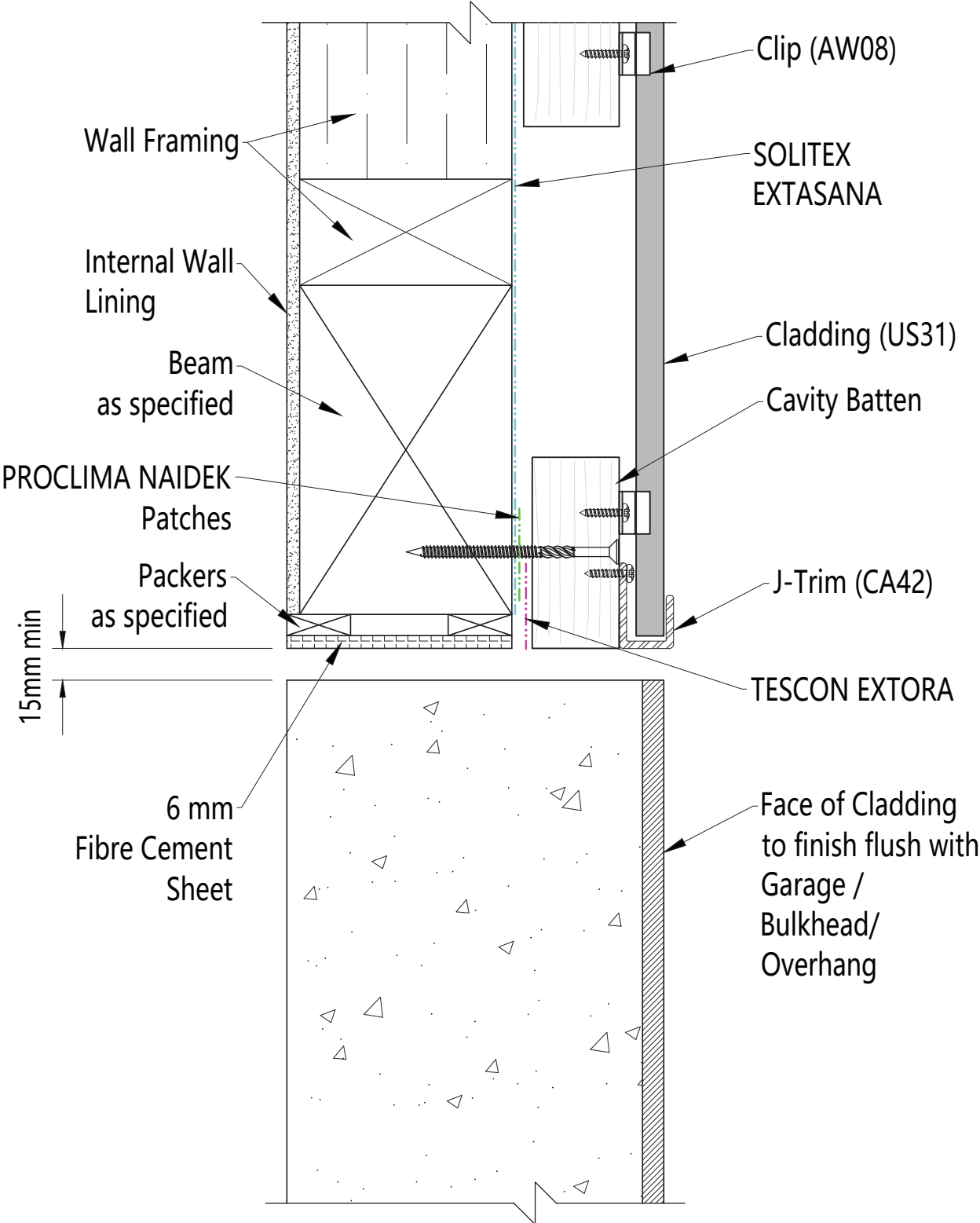

5.2.17 Metal Capping Parapet Wall to Box Gutter

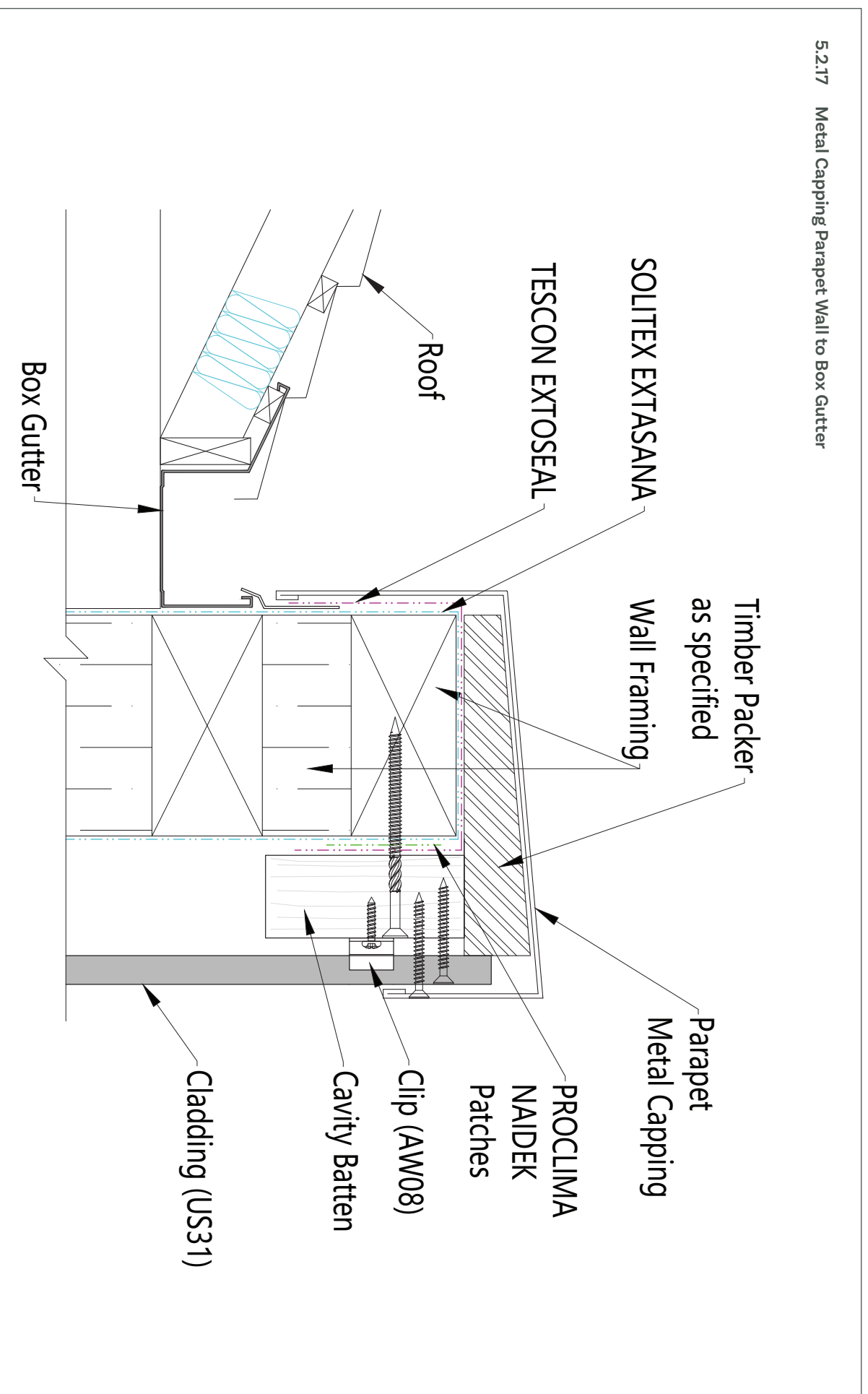

5.2.18 Metal Capping Parapet Wall to Roof

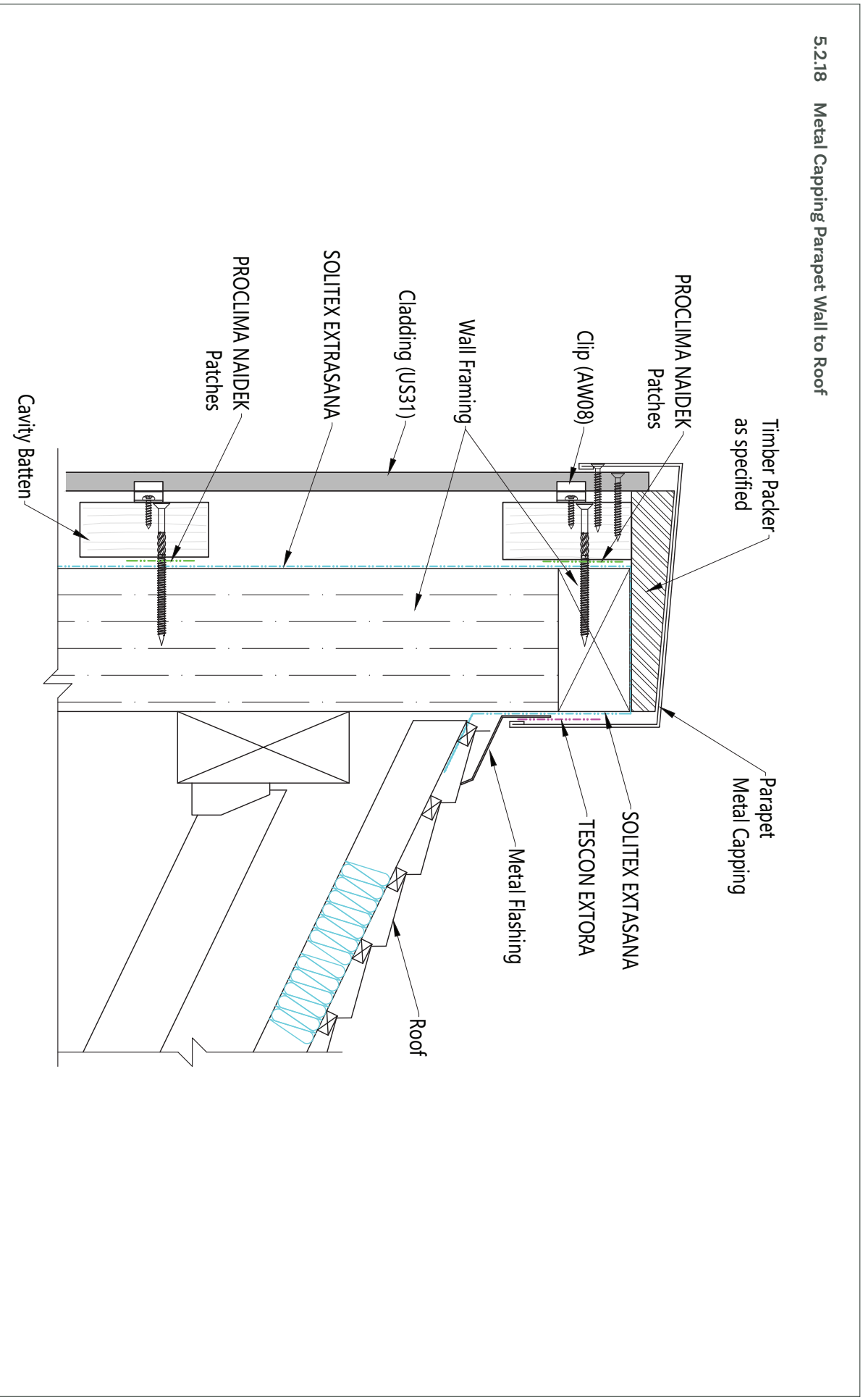

5.2.19 Outside Corner

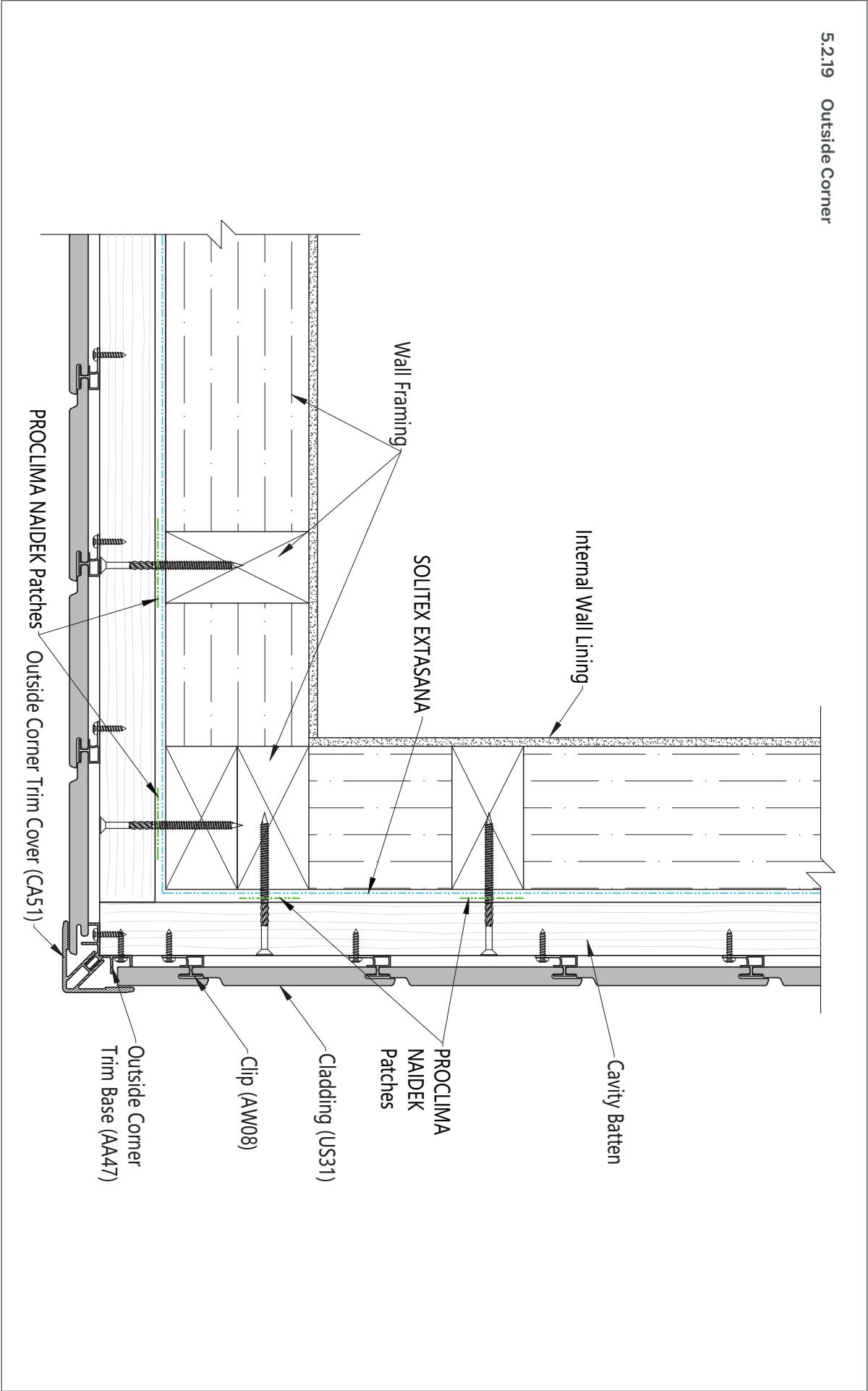

5.2.20 Inside Corner

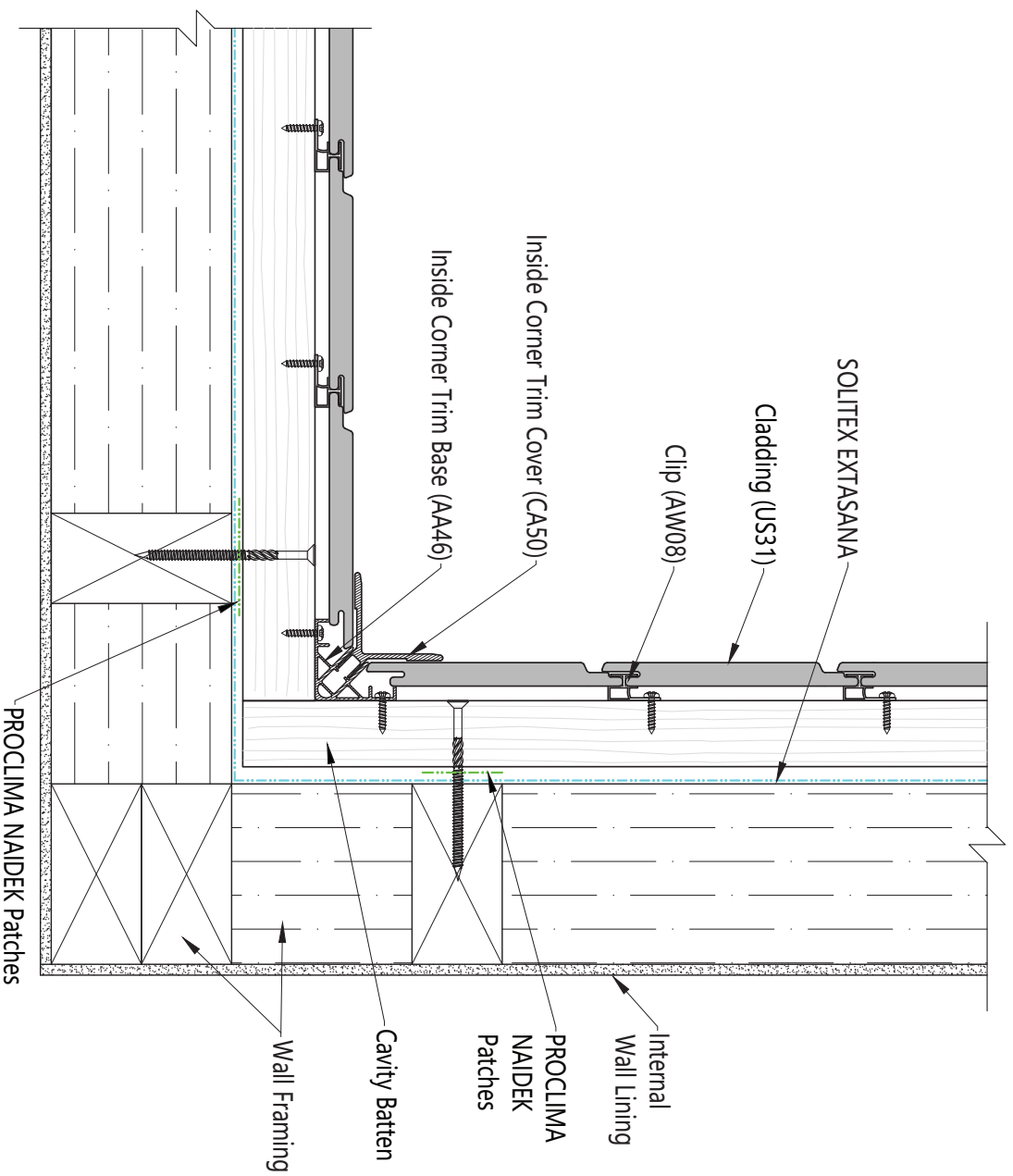

5.2.21 Wall Over Roof

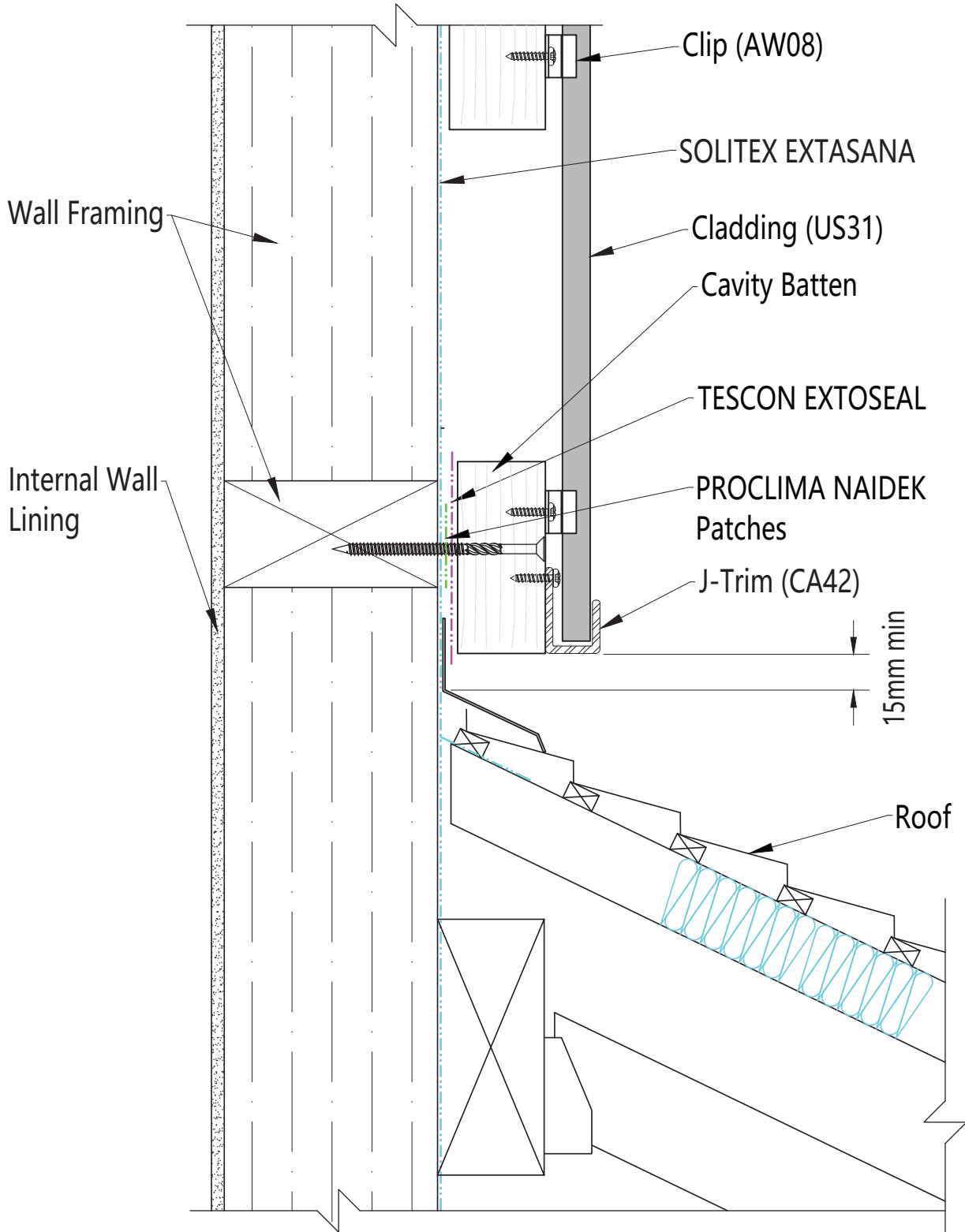



5.2.22 Outermost Edge

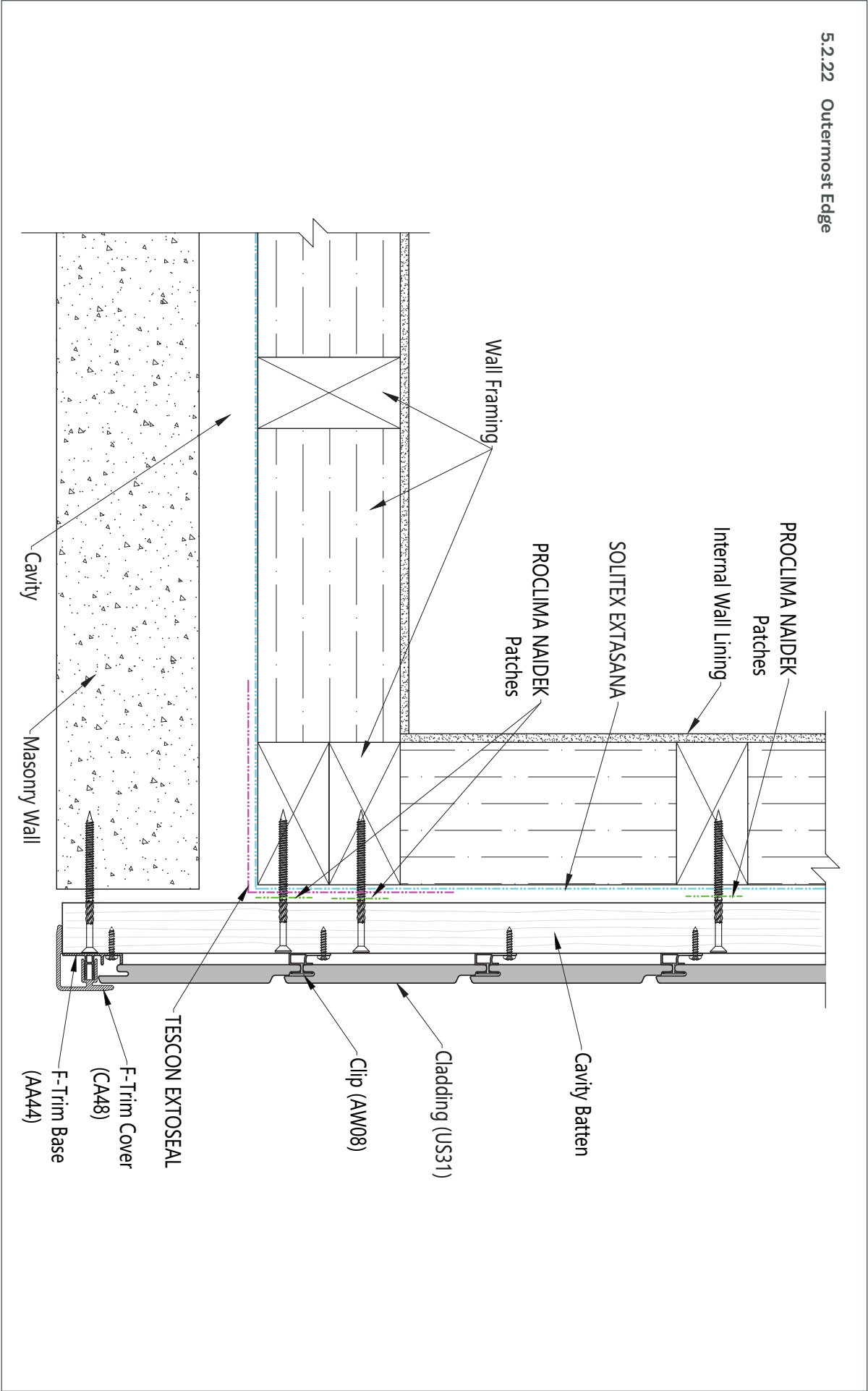

## 6 Manufacturer's Warranty

Backed by a 25-Year Residential Warranty

Whilst we back our products with confidence, you can have peace of mind knowing we offer the most comprehensive residential warranty on all NewTechWood composite decking, cladding and screening products.

It is essential that installation is completed per the installation guide, to ensure your cladding is installed perfectly.

For commercial projects, a 10-year commercial Warranty applies.

Up to date Information on NewTechWood Shadowline Wall Cladding System can be found at:  
<https://newtechwood.com.au/warranty/>

Distributed in Australia by:  
Urban Direct Wholesale Pty Ltd (ACN 608 304 945)  
24 Tichborne Street, Cockburn Central Western Australia 6164  
Telephone: (08) 9494 1051  
Email: [info@urbandirectwholesale.com.au](mailto:info@urbandirectwholesale.com.au)